

## Refrigeration Information

### Basic Refrigeration Cycle

Mechanical refrigeration is accomplished by a continuously circulating, evaporating and condensing a fixed supply of refrigerant in a closed system. Evaporation occurs at a low temperature and low pressure while condensation occurs at a high temperature and high pressure. Thus, it is possible to transfer heat from an area of low temperature (i.e., refrigerator cabinet) to an area of high temperature (i.e., kitchen).

Beginning the cycle at the evaporator inlet (1) the low pressure liquid expands, absorbs heat and evaporates, changing to a low pressure gas at the evaporator outlet (2).

The compressor (4) pumps this gas from the evaporator through the accumulator (3), increases its pressure, and discharges the high pressure gas to the condenser (5). The accumulator is designed to protect the compressor by preventing slugs of liquid refrigerant from passing directly into the compressor. An accumulator should be included on all systems subjected to varying load conditions or frequent compressor cycling. In the condenser, heat is removed from the gas, which then condenses and becomes a high pressure liquid. In some systems, this high pressure liquid drains from the condenser into a liquid storage or receiver tank (6). On other systems, both the receiver and the liquid line valve (7) are omitted.

A heat exchanger (8) between the liquid line and the suction line is also an optional item, which may or may not be included in a given system design.

Between the condenser and the evaporator an expansion device (10) is located. Immediately preceding this device is a liquid line strainer/drier (9), which prevents plugging of the valve or tube by retaining scale, dirt and moisture. The flow of refrigerant into the evaporator is controlled by the pressure differential across the expansion device or, in the case of a thermal expansion valve, by the degree of superheat of the suction gas. Thus, the thermal expansion valve shown requires a sensor bulb located at the evaporator outlet. In any case, the flow of refrigerant into the evaporator normally increases as the evaporator load increases.

As the high pressure liquid refrigerant enters the evaporator, it is subjected to a much lower pressure due to the suction of the compressor and the pressure drop across the expansion device. Thus, the refrigerant tends to expand and evaporate. In order to evaporate, the liquid must absorb heat from the air passing over the evaporator.

Eventually, the desired air temperature is reached and the thermostat or cold control (11) will break the electrical circuit to the compressor motor and stop the compressor.

As the temperature of the air through the evaporator rises, the thermostat or cold control remakes the electrical circuit. The compressor starts, and the cycle continues.

In addition to the accumulator, a compressor crankcase heater (12) is included on many systems. This heater prevents accumulation of refrigerant in the compressor crankcase during the nonoperating periods and prevents liquid slugging or oil pump-out on startup.

Additional protection to the compressor and system is afforded by a high and low pressure cutout (13). This control is set to stop the compressor in the event that the system pressures rise above or fall below the design operating range.

Other controls not indicated on the basic cycle which may be part of a system include: evaporator pressure regulators, hot gas by-pass regulators, electric solenoid valves, suction pressure regulators, condenser pressure regulators, low side or high side float refrigerant controllers, oil separators, etc.

It is extremely important to analyze completely every system and understand the intended function of each component before attempting to determine the cause of a malfunction or failure.

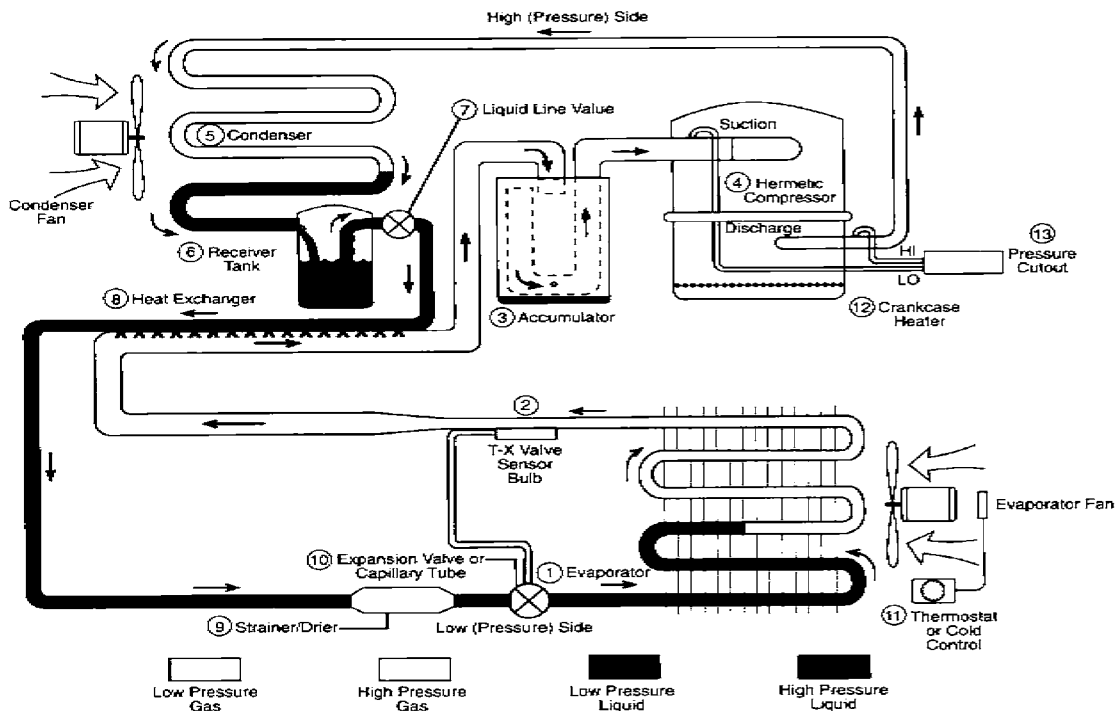

## Split Troubleshooting AC Guide

Company name \_\_\_\_\_ Technician name \_\_\_\_\_ Date \_\_\_\_\_

Customer name \_\_\_\_\_ Indoor wet bulb \_\_\_\_\_ Indoor dry bulb \_\_\_\_\_ Outdoor dry bulb \_\_\_\_\_

Design suction pressure on charging chart \_\_\_\_\_ Design discharge pressure on charging chart \_\_\_\_\_

Outdoor temp next to condenser \_\_\_\_\_ Primary voltage (loaded) \_\_\_\_\_ Secondary (low) voltage \_\_\_\_\_

Amps to outdoor motor \_\_\_\_\_ Compressor amps: Common \_\_\_\_\_ Run \_\_\_\_\_ Start \_\_\_\_\_

Capacitor rating \_\_\_\_\_

Return temp at grill \_\_\_\_\_ Return temp at unit \_\_\_\_\_

Supply temp at unit \_\_\_\_\_ Supply temp at registers \_\_\_\_\_  
shortest run middle run furthest run

Blower speed tap for PSC & CTM
Cooling CFM setting on VS motor
Heating CFM setting on VS motor

Number of green CFM flashes at air handler \_\_\_\_\_

Leaving air temp \_\_\_\_\_

Temp drop across dryer and check valve \_\_\_\_\_

Discharge temp \_\_\_\_\_

Discharge press \_\_\_\_\_

Suction press \_\_\_\_\_

Temp rise on suction lines across valve \_\_\_\_\_

Liquid pressure \_\_\_\_\_

Vapor pressure \_\_\_\_\_



Line set length \_\_\_\_\_

Line sizes \_\_\_\_\_

Lift & # elbows \_\_\_\_\_

Vapor line temp \_\_\_\_\_

Liquid line temp \_\_\_\_\_

Superheat \_\_\_\_\_

Subcooling \_\_\_\_\_

Liquid line temp \_\_\_\_\_

Vapor line temp \_\_\_\_\_

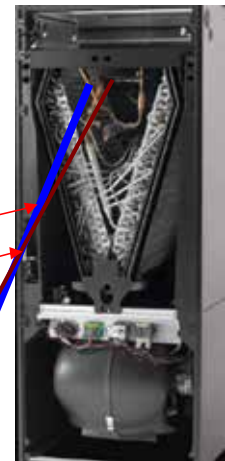

Return static with filter \_\_\_\_\_ Return static w/o filter \_\_\_\_\_ Filter type \_\_\_\_\_ Filter size \_\_\_\_\_

Supply static with filter \_\_\_\_\_

Condenser Model # \_\_\_\_\_ Condenser Serial # \_\_\_\_\_

Air Handler Model # \_\_\_\_\_ Air Handler Serial # \_\_\_\_\_

Coil Model # \_\_\_\_\_ Coil Serial # \_\_\_\_\_

Furnace Model # \_\_\_\_\_ Furnace Serial # \_\_\_\_\_

**Refer to manufacturer's instructions and local codes.**

## AC/Refrigeration: Measuring Liquid Subcooling Level

You must measure the liquid subcooling level to confirm there is adequate refrigerant charge in the condenser coil.

Inadequate subcooling could cause flash gas to form in the liquid line.  
Excessive shooting is an indication of an overcharged system.

### REQUIRED TOOLS: DIGITAL TEMPERATURE PROBE, REFRIGERATION GAUGES

1. Run the condensing unit until pressures and temperature stabilize.
2. Read and record the liquid pressure at the liquid line pressure port fitting at the condensing unit.
3. Place a digital temperature probe against the liquid line near the liquid gauge pressure port. Read and record the temperature.
4. Reference the face of your high pressure gauge or use a temperature/pressure chart and convert the measured liquid pressure to the corresponding condenser coil saturation temperature for the refrigerant being used. Record this value.
5. Next, subtract the measured liquid line temperature from saturation temperature. The result is your actual liquid subcooling level.



### FORMULA:

$$\frac{\text{Saturation Temperature} - \text{Liquid Line Temperature}}{\text{Liquid Subcooling}}$$

### EXAMPLE:

Refrigerant: R-410A

Liquid Line Pressure: 320 PSIG

Corresponding Condenser Saturation Temperature 100°F

Liquid Line Temperature: 90°F

100°F - 90°F = Liquid Subcooling

Liquid Subcooling = 10°F

## Refrigeration Troubleshooting

PROBLEM	POSSIBLE CAUSES	POSSIBLE CORRECTIVE STEPS
Compressor will not run	<ol style="list-style-type: none"> <li>1. Main switch open.</li> <li>2. Fuse blown.</li> <li>3. Thermal overloads tripped.</li> <li>4. Defective contactor or coil.</li> <li>5. System shut down by safety devices.</li> <li>6. No cooling required.</li> <li>7. Liquid line solenoid will not open.</li> <li>8. Motor electrical trouble.</li> <li>9. Loose wiring.</li> <li>10. Phase loss monitor inoperative.</li> </ol>	<ol style="list-style-type: none"> <li>1. Close switch.</li> <li>2. Check electrical circuits and motor winding for shorts or grounds. Investigate for possible overloading. Replace fuse after fault is corrected.</li> <li>3. Overloads are automatically reset. Check unit closely when unit comes back on line.</li> <li>4. Repair or replace.</li> <li>5. Determine type and cause of shutdown and correct it before resetting safety switch.</li> <li>6. None. Wait until calls for cooling.</li> <li>7. Repair or replace coil.</li> <li>8. Check motor for open windings, short circuit or burn out.</li> <li>9. Check all wire junctions. Tighten all terminal screws.</li> <li>10. Refer to page 18.</li> </ol>
Compressor noisy or vibrating	<ol style="list-style-type: none"> <li>1. Flooding of refrigerant into crankcase.</li> <li>2. Improper piping support on suction or liquid line.</li> <li>3. Worn compressor.</li> <li>4. Scroll compressor rotation reversed.</li> </ol>	<ol style="list-style-type: none"> <li>1. Check setting of expansion valves.</li> <li>2. Relocate, add or remove hangers.</li> <li>3. Replace.</li> <li>4. Rewire for phase change.</li> </ol>
High discharge pressure	<ol style="list-style-type: none"> <li>1. Non-condensables in system.</li> <li>2. System overcharges with refrigerant.</li> <li>3. Discharge shutoff valve partially closed.</li> <li>4. Fan not running.</li> <li>5. Head pressure control setting.</li> <li>6. Dirty condenser coil.</li> </ol>	<ol style="list-style-type: none"> <li>1. Remove the non-condensables.</li> <li>2. Remove excess.</li> <li>3. Open valve.</li> <li>4. Check electrical circuit.</li> <li>5. Adjust.</li> <li>6. Clean.</li> </ol>
Low discharge pressure	<ol style="list-style-type: none"> <li>1. Faulty condenser temperature regulation.</li> <li>2. Suction shutoff valve partially closed.</li> <li>3. Insufficient refrigerant in system.</li> <li>4. Low suction pressure.</li> <li>5. Variable head pressure valve.</li> </ol>	<ol style="list-style-type: none"> <li>1. Check condenser control operation.</li> <li>2. Open valve.</li> <li>3. Check for leaks. Repair and add charge.</li> <li>4. See corrective steps for low suction pressure.</li> <li>5. Check valve setting.</li> </ol>
High suction pressure	<ol style="list-style-type: none"> <li>1. Excessive load.</li> <li>2. Expansion valve overfeeding.</li> </ol>	<ol style="list-style-type: none"> <li>1. Reduce load or add additional equipment.</li> <li>2. Check remote bulb. Regulate superheat.</li> </ol>
Low suction pressure	<ol style="list-style-type: none"> <li>1. Lack of refrigerant.</li> <li>2. Evaporator dirty or iced.</li> <li>3. Clogged liquid line filter drier.</li> <li>4. Clogged suction line or compressor suction gas strainers.</li> <li>5. Expansion valve malfunctioning.</li> <li>6. Condensing temperature too low.</li> <li>7. Improper TXV.</li> </ol>	<ol style="list-style-type: none"> <li>1. Check for leaks. Repair and add charge.</li> <li>2. Clean.</li> <li>3. Replace cartridge(s).</li> <li>4. Clean strainers.</li> <li>5. Check and reset for proper superheat.</li> <li>6. Check means for regulating condensing temperature.</li> <li>7. Check for proper sizing.</li> </ol>
Little or no oil pressure	<ol style="list-style-type: none"> <li>1. Clogged suction oil strainer.</li> <li>2. Excessive liquid in crankcase.</li> <li>3. Low oil pressure safety switch defective.</li> <li>4. Worn oil pump.</li> <li>5. Oil pump reversing gear stuck in wrong position.</li> <li>6. Worn bearings.</li> <li>7. Low oil level.</li> <li>8. Loose fitting on oil lines.</li> <li>9. Pump housing gasket leaks.</li> </ol>	<ol style="list-style-type: none"> <li>1. Clean.</li> <li>2. Check crankcase heater. Reset expansion valve for higher superheat. Check liquid line solenoid valve operation.</li> <li>3. Replace.</li> <li>4. Replace.</li> <li>5. Reverse direction of compressor rotation.</li> <li>6. Replace compressor.</li> <li>7. Add oil and/or through defrost.</li> <li>8. Check and tighten system.</li> <li>9. Replace gasket.</li> </ol>
Compressor loses oil	<ol style="list-style-type: none"> <li>1. Lack of refrigerant.</li> <li>2. Excessive compression ring blowby.</li> <li>3. Refrigerant flood back.</li> <li>4. Improper piping or traps.</li> </ol>	<ol style="list-style-type: none"> <li>1. Check for leaks and repair. Add refrigerant.</li> <li>2. Replace compressor.</li> <li>3. Maintain proper superheat at compressor.</li> <li>4. Correct piping.</li> </ol>
Compressor thermal protector switch open.	<ol style="list-style-type: none"> <li>1. Operating beyond design conditions.</li> <li>2. Discharge valve partially shut.</li> <li>3. Blown valve plate gasket.</li> <li>4. Dirty condenser coil.</li> <li>5. Overcharged system.</li> </ol>	<ol style="list-style-type: none"> <li>1. Add facilities so that conditions are within allowable limits.</li> <li>2. Open valve.</li> <li>3. Replace gasket.</li> <li>4. Clean coil.</li> <li>5. Reduce charge.</li> </ol>

## Furnace Troubleshooting Guide

Company name \_\_\_\_\_ Technician name \_\_\_\_\_ Date \_\_\_\_\_

Customer name \_\_\_\_\_

Flash code \_\_\_\_\_ Elevation of home \_\_\_\_\_ High altitude kit used \_\_\_\_\_ Natural or LP gas \_\_\_\_\_

Primary voltage: Hot to neutral \_\_\_\_\_ Hot to ground \_\_\_\_\_

Neutral to ground \_\_\_\_\_ Line neutral to 24 V common \_\_\_\_\_ Flame rectification \_\_\_\_\_

Secondary voltage \_\_\_\_\_ Is secondary physically grounded \_\_\_\_\_ Low fire pressure \_\_\_\_\_

Inlet gas pressure \_\_\_\_\_ High fire pressure \_\_\_\_\_

Return temp at grill \_\_\_\_\_ Return temp at unit \_\_\_\_\_

Supply temp at unit \_\_\_\_\_ Supply temp at registers \_\_\_\_\_  
shortest run      middle run      furthest run

Blower speed tap for PSC & CTM
Cooling CFM setting on VS motor
Heating CFM setting on VS motor

Number of green CFM flashes at furnace \_\_\_\_\_

Combustion blower amps \_\_\_\_\_ System blower amps \_\_\_\_\_ Flue size \_\_\_\_\_

Length of flue \_\_\_\_\_ # of elbows \_\_\_\_\_ # of 45's \_\_\_\_\_

Combustion length \_\_\_\_\_ # of elbows \_\_\_\_\_ # of 45's \_\_\_\_\_



High fire vent pressure on 80% \_\_\_\_\_

High fire vent pressure differential between combustion box and secondary heat exchanger on 90+% \_\_\_\_\_



Return static with filter \_\_\_\_\_ Return static w/o filter \_\_\_\_\_ Filter type \_\_\_\_\_ Filter size \_\_\_\_\_

Furnace position: Upflow \_\_\_\_\_ Downflow \_\_\_\_\_

Supply static above coil (w/filter in place) \_\_\_\_\_ Supply static between furnace & coil if possible (w/filter) \_\_\_\_\_

Horizontal laying on left side \_\_\_\_\_ Horizontal laying on right side \_\_\_\_\_

Furnace Model # \_\_\_\_\_ Furnace Serial # \_\_\_\_\_

Coil Model # \_\_\_\_\_ Condenser Model # \_\_\_\_\_

Models and Specifications are Subject to Change Without Notice

## Air Flow in CFM Gas Fired Furnace

$$\text{CFM} = \frac{\text{BTU OUTPUT}}{\text{TEMP RISE} \times 1.08}$$

### EXAMPLE:

SUPPLY AIR = 150°

RETURN AIR = 75°

TEMP RISE = 75°

75 x 1.08 = 81°

FURNACE OUTPUT = 100,000 BTU

$$\frac{100,000}{81} = 1235 \text{ CFM}$$

### NOTES:

- Switch cooling and heating speeds on board
- Make sure furnace gas pressure = 3.5" BTU
- Wait ten minutes before measuring temperature

## Furnace Fault Diagnostics

LED FLASH	LED FLASH
Slow Flash	Normal standby
Fast Flash	Normal with a call for heat.
Continuous ON	Internal fault in the IFC.
2 Flashes	System lockout - no flame. Total of three tries. Automatic reset in one hour.
3 Flashes	Pressure switch error. (Fault may be caused by a vent problem or a wiring connection in the switch circuit.) On two speed furnaces, if there is a high heat pressure switch fault, the IFC will not lock out. It will go back to low heat, cancel the three flash indication for ten minutes and again try high heat.
4 Flashes	Thermal protection device open.
5 Flashes	Flame being sensed with gas valve de-energized (stuck open). Vent motor and indoor blower will be energized.
6 Flashes	No ground or power leads to furnace reversed, or line voltage too low.
7 Flashes	20VAC at gas valve with no call for heat or if no flame is present; keep vent motor on.
8 Flashes	Low flame sense signal.
9 Flashes	Ignitor fault or improper ground or low voltage.

### 2 Flash code:

- HSI Check (sini) 11-18 ohms & 85 volts
- Flame sensor 2-4 DCMA 1 MIN
- Inlet & Manifold pressure 5' min. inlet
- 1.4" - 1.7" 1st stage 3.5" 2nd stage nat.
- 6.0" 1st stage 10.5" - 11" 2nd stage lp

### 3 Flash code:

- Monitor negative pressure developed by inducer
- Check against pressure switch rating
- Check for restriction in vent
- Check to see if inducer is running at correct speed

### 4 Flash code:

- Check filter
- Check blower operation
- Check supply and return registers
- Measure static pressure
- For flame rollout check inducer, vent pipe
- Combustion air

### 5 Flash code:

- DO NOT TURN OFF POWER
- Check for grounded flame sensor
- Replace gas valve

### 6 Flash code:

- Voltage check 120 hot to neutral
- Neutral to ground should be 0 volts
- Check furnace grounds
- IFC CNT4677 & 4678 ohm & volt check
- On HSI

### 7 Flash code:

- Check for 24 volts at gas valve & IFC
- Valve energized before HSI replace IFC

### 8 Flash code:

- Check flame sensor, clean

### 9 Flash code:

- Ohm ignitor 11 - 18 for sini
- Check ground
- Check voltage between neutral & b/c term on IFC less than 2 vac
- CNT4677 & 4678 boards inducer limit open



## Furnace Fault Diagnostics

The diagnostics will indicate the specific fault through the following code:

GREEN LED FLASH	AMBER LED FLASH	RED LED FLASH	ERROR
		1	Flame sensed when no flame should be present
		2	Pressure switch stuck closed
		3	1st stage pressure switch is open / not closing
		4	Open thermal limit or open rollout
		5	Open low voltage fuse
		6	1st stage pressure switch opened 5 times within one cycle—1 hour lockout
		7	System lockout - retry
		8	System lockout - recycle
		9	Reverse polarity or poor grounding
		10	Gas valve energized without call for heat
		12	Ignitor relay failure internal in board. Replace IFC
		Solid	Gas valve relay failure internal board. Replace IFC
		3 Double	2nd stage pressure switch open; system reverts back to 1st stage heat
	1		1st stage call for heat
	2		2nd stage call for heat
	3		W2 call present without W1
	4		Y call present withough G
	Rapid		Low flame sense current
1			Standby mode or call for cooling

## Gas Piping Information

**TABLE 402.3(1)**  
**MAXIMUM CAPACITY OF PIPE IN CUBIC FEET OF GAS PER HOUR FOR GAS PRESSURES OF 0.5 PSI OR LESS AND A PRESSURE DROP OF 0.3-INCH WATER COLUMN**  
**Based on a 0.60 Specific Gravity Gas**

NOMINAL IRON PIPE SIZE (inches)	INTERNAL DIAMETER (inches)	LENGTH OF PIPE (feet)													
		10	20	30	40	50	60	70	80	90	100	125	150	175	200
1/4	.364	32	22	18	15	14	12	11	11	10	9	8	8	7	6
3/8	.493	72	49	40	34	30	27	25	23	22	21	18	17	15	14
1/2	.622	132	92	73	63	56	50	46	43	40	38	34	31	28	26
3/4	.824	278	190	152	130	115	105	96	90	84	79	72	64	59	55
1	1.049	520	350	285	245	215	195	180	170	160	150	130	120	110	100
1 1/4	1.380	1,050	730	590	500	440	400	370	350	320	305	275	250	225	210
1 1/2	1.610	1,600	1,100	890	760	670	610	560	530	490	460	410	380	350	320
2	2.067	3,050	2,100	1,650	1,450	1,270	1,150	1,050	990	930	870	780	710	650	610
2 1/2	2.469	4,800	3,300	2,700	2,300	2,000	1,850	1,700	1,600	1,500	1,400	1,250	1,130	1,050	980
3	3.068	8,500	5,900	4,700	4,100	3,600	3,250	3,000	2,800	2,600	2,500	2,200	2,000	1,850	1,700
4	4.026	17,500	12,000	9,700	8,300	7,400	6,800	6,200	5,800	5,400	5,100	4,500	4,100	3,800	3,500

For SI: 1 inch = 25.4 mm, 1 foot = 304.8 mm, 1 cubic foot per hour = 0.0283 m<sup>3</sup>/h, 1 pound per square inch = 6.895 kPa, 1-inch water column = 0.2488 kPa.

**TABLE 402.3(2)**  
**MAXIMUM CAPACITY OF PIPE IN CUBIC FEET OF GAS PER HOUR FOR GAS PRESSURES OF 0.5 PSI OR LESS AND A PRESSURE DROP OF 0.5-INCH WATER COLUMN**  
**Based on a 0.60 Specific Gravity Gas**

NOMINAL IRON PIPE SIZE (inches)	INTERNAL DIAMETER (inches)	LENGTH OF PIPE (feet)													
		10	20	30	40	50	60	70	80	90	100	125	150	175	200
1/4	.364	43	29	24	20	18	16	15	14	13	12	11	10	9	8
3/8	.493	95	65	52	45	40	36	33	31	29	27	24	22	20	19
1/2	.622	175	120	97	82	73	66	61	57	53	50	44	40	37	35
3/4	.824	360	250	200	170	151	138	125	118	110	103	93	84	77	72
1	1.049	680	465	375	320	285	260	240	220	205	195	175	160	145	135
1 1/4	1.380	1,400	950	770	660	580	530	490	460	430	400	360	325	300	280
1 1/2	1.610	2,100	1,460	1,180	990	900	810	750	690	650	620	550	500	460	430
2	2.067	3,950	2,750	2,200	1,900	1,680	1,520	1,400	1,300	1,220	1,150	1,020	950	850	800
2 1/2	2.469	6,300	4,350	3,520	3,000	2,650	2,400	2,250	2,050	1,950	1,850	1,650	1,500	1,370	1,280
3	3.068	11,000	7,700	6,250	5,300	4,750	4,300	3,900	3,700	3,450	3,250	2,950	2,650	2,450	2,280
4	4.026	23,000	15,800	12,800	10,900	9,700	8,800	8,100	7,500	7,200	6,700	6,000	5,500	5,000	4,600

For SI: 1 inch = 25.4 mm, 1 foot = 304.8 mm, 1 cubic foot per hour = 0.0283 m<sup>3</sup>/h, 1 pound per square inch = 6.895 kPa, 1-inch water column = 0.2488 kPa.

## Meter Clocking Method

### Meter Clocking Method

**Caution:** Make certain there is no gas flow through the meter other than to the appliance being checked.  
Use Table to determine exact rate of gas flow to appliance.

#### METER FLOW RATE – CUBIC FEET PER HOUR (cfh).

To convert cfh to cubic meter per hour (M<sup>3</sup>/hr) multiply by .0283.

Sec for One Rev.	Meter Dial Used - Cu. Ft. per Rev.		Sec for One Rev.	Meter Dial Used - Cu. Ft. per Rev.			Sec for One Rev.	Meter Dial Used - Cu. Ft. per Rev.		
	1/2	1		1/2	1	2		1	2	5
10	180	360	35	52	103	206	60	60	120	300
11	164	327	36	50	100	200	62	58	116	290
12	150	300	37	49	97	195	64	56	112	281
13	139	277	38	48	95	189	66	55	109	273
14	129	257	39	46	92	185	68	53	106	265
15	120	240	40	45	90	180	70	52	103	257
16	113	225	41	44	88	176	72	50	100	250
17	106	212	42	43	86	172	74	49	97	243
18	100	200	43	42	84	167	76	48	95	237
19	95	189	44	41	82	164	78	46	92	231
20	90	180	45	40	80	160	80	45	90	225
21	86	171	46	39	78	157	84	43	86	214
22	82	164	47	38	77	153	88	41	82	205
23	78	157	48	38	75	150	92	39	78	196
24	75	150	49	37	74	147	96	38	75	188
25	72	144	50	36	72	144	100	36	72	180
26	69	138	51	35	71	141	105	34	69	172
27	67	133	52	35	69	138	110	33	66	164
28	64	129	53	34	68	136	120	30	60	150
29	62	124	54	33	67	133	130	28	55	138
30	60	120	55	33	66	131	140	26	52	129
31	58	116	56	32	64	129	150	24	48	120
32	56	113	57	32	63	126	160	23	45	113
33	55	109	58	31	62	124	170	21	43	106
34	53	106	59	31	61	122	180	20	40	100

To convert meter flow rate (cfh) to BTU per hour, multiply cfh (from table above) by the BTU heat content of the gas being used.

To convert input rating (BTU per hour as stamped on appliance nameplate) to meter flow rate (cfh).

Input rating in BTU per hour.

Input BTU/Hr. Per Spud	Natural Gas 1020 BTU - .65 SG 3-1/2" WC Manifold		Propane 2500 BTU - 1.5 SG 11" WC Manifold	
	Drill Size	Decimal Tolerance	Drill Size	Decimal Tolerance
12,000	51	.064 - .067	60	.038 - .040
15,000	48	0.73 - .076	58	.040 - .042
20,000	43	.086 - .089	55	.050 - .052
25,000	41	.093 - .096	53	.056 - .059
27,500	39	.097 - .100	53	.060 - .063
40,000	32	.113 - .116	49	.070 - .073
50,000	30	.124 - .128	46	.078 - .081
60,000	27	.140 - .144	43	.086 - .089
70,000	22	.153 - .157	42	.090 - .093
80,000	20	.156 - .161	40	.095 - .098
90,000	17	.168 - .173	38	.098 - .101
100,000	13	.180 - .185	35	.107 - .110
105,000	11	.186 - .191	34	.108 - .111
110,000	10	.188 - .193	33	.109 - .113
125,000	5	.200 - .205	1/8	.121 - .125
135,000	3	.208 - .213	30	.124 - .128
140,000	7/32	.214 - .219	30	.124 - .128
150,000	1	.223 - .228	29	.132 - .136
160,000	A	.229 - .234	28	.136 - .140
175,000	C	.237 - .242	27	.140 - .144
190,000	E	.245 - .250	25	.145 - .149
200,000	F	.252 - .257	23	.150 - .154
210,000	H	.261 - .266	21	.154 - .159
220,000	I	.267 - .272	20	.156 - .161
240,000	K	.276 - .281	18	.164 - .169
260,000	M	.290 - .295	16	.172 - .177
280,000	5/16	.307 - .312	13	.180 - .185
300,000	O	.311 - .316	11	.186 - .191
310,000	P	.318 - .323	9	.191 - .196
320,000	21/64	.323 - .328	7	.196 - .201

## Meter Flue Venting

HEIGHT	CONNECTION	LATERAL	DIAMETER - "D" (inches)														
			3"		4"		5"		6"		7"						
			APPLIANCE INPUT RATING (Thousands of BTU per Hour)														
			FAN		NAT		FAN		NAT		FAN		NAT				
MIN	MAX	MIN	MAX	MIN	MAX	MIN	MAX	MIN	MAX	MIN	MAX						
15'	Double	9'	22	52	38	30	104	70	38	179	114	48	264	174	84	375	240
		10'	29	47	33	40	87	66	51	105	108	64	252	166	84	356	230
15'	Single	9'	50	51	35	75	102	68	182	173	112	144	261	174	192	367	238
		10'	-	-	31	93	95	63	128	161	105	182	246	162	228	300	227
25'	Double	9'	31	60	41	29	121	82	37	207	135	46	316	206	60	448	289
		10'	28	54	38	38	113	77	49	197	129	51	383	196	79	432	227
25'	Single	9'	40	57	40	73	119	80	39	234	132	139	312	204	175	444	282
		10'	-	-	-	95	109	74	124	191	126	174	297	193	218	405	274
30'	Double	9'	21	62	43	28	128	86	36	220	141	48	327	218	58	480	308
		10'	27	56	45	37	120	82	48	219	137	56	324	209	77	464	297
30'	Single	9'	49	59	42	72	126	85	36	217	138	136	324	217	171	476	306
		10'	-	-	-	91	105	78	122	204	134	171	318	206	213	456	294
35'	Double	9'	21	63	32	28	132	88	36	228	146	45	380	225	57	501	319
		10'	27	57	35	37	124	84	47	217	141	56	327	216	76	484	308
35'	Single	9'	40	68	-	72	129	87	57	224	143	135	347	224	168	496	317
		10'	-	-	-	91	118	83	121	212	138	169	331	213	211	476	305
40'	Double	9'	21	65	-	28	139	93	36	243	156	44	377	239	57	642	340
		10'	27	60	-	36	121	89	47	232	149	58	364	231	75	525	328
40'	Single	9'	49	63	-	71	136	92	36	239	152	134	373	238	168	537	328
		10'	-	-	-	90	125	82	120	227	148	157	356	227	208	517	328

HEIGHT	CONNECTION	Common Vent Diameter - "D" (inches)														
		3"		4"		5"		6"		7"						
		APPLIANCE INPUT RATING (Thousands of BTU per Hour)														
		FAN		NAT		FAN		NAT		FAN		NAT				
MIN	MAX	MIN	MAX	MIN	MAX	MIN	MAX	MIN	MAX	MIN	MAX					
15'	Double	100	90	73	153	131	115	227	182	165	342	282	224	445	355	292
		97	86	70	151	127	112	220	177	160	333	274	219	435	347	285
25'	Double	116	104	88	184	157	138	270	221	198	409	341	268	537	434	350
		111	100	84	178	152	134	262	214	192	398	332	261	524	423	342
30'	Double	122	110	94	195	168	148	289	238	213	438	367	288	576	468	376
		116	106	90	189	162	143	280	229	206	426	357	279	562	456	367
35'	Double	125	113	98	202	175	154	301	249	222	457	385	300	603	492	392
		119	109	93	195	168	148	291	239	214	444	374	291	588	479	382
45'	Double	151	119	104	216	189	166	325	271	240	494	420	326	656	541	424
		124	114	98	208	180	158	314	260	229	480	407	316	640	526	413

### REQUIREMENTS FOR GENERAL VENTING

- 1) Tru-Life™ systems are UL Listed for masonry chimneys that serve Category I appliances fired with propane or natural gas.
- 2) A "listed" liner or a tile liner that conforms to code must be used when venting gas-fired appliances into unlined masonry chimneys. Cracked or misaligned tiles do not qualify as a "code" liner.
- 3) A "listed" lining system must be installed when venting "fan assisted" appliance, on their own, into tile-lined chimneys.
- 4) Other appliances must not be vented into the air space around an installed Tru-Life™ system.
- 5) The outlet of the appliance being served may be larger in diameter than the Tru-Life™ system only if:
  - a) the vent is at least ten feet high.
  - b) the liner is no less than one table size smaller.
  - c) fan-assisted appliances reduced the "FAN MAX" by 10%.
  - d) "natural draft" appliances have an outlet larger than 4 inches.
- 6) A Tru-Life™ system that vents multiple appliances must have a diameter no smaller than the largest appliance outlet.
- 7) The smallest allowable Tru-Life™ diameter is preferred if the tables permit a choice.
- 8) In a vent system with more than two 90° elbows, each additional elbow or equivalent offset requires reducing the system's maximum capacity by 10%.
- 9) The installation of vent connectors must conform to the current National Fuel Gas Code: NFPA-54.
- 10) Gas vent installations must meet local code requirements.

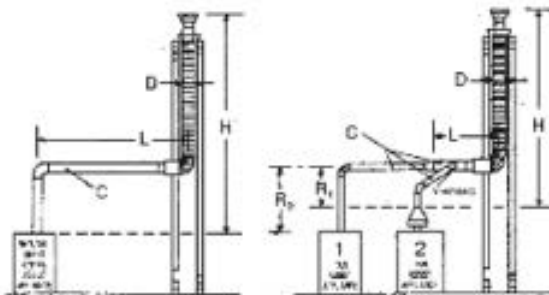

## Furnace Quick Check Motor Will Not Run

These service procedures will work on ECM-2™ motors and their motor control board and their 16 wire low voltage control cable.

### 1. Jumper 24 Volt A.C. "R" terminal to "G" terminal on the low voltage terminal board.

Does motor run?

**No:** Go to step #2

**Yes:** Motor runs, check comfort control and comfort control wire.

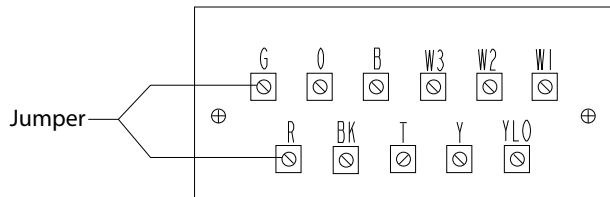

### 3. Unplug 16 wire low voltage harness from the motor. Jumper 24 volts A.C. to motor low voltage plug pins #12 and #15 and pins #1 and #3 which are common.

Does motor run?

**No:** Got to step #4.

**Yes:** Fault is in the 16 wire low voltage harness. Repair or replace it.

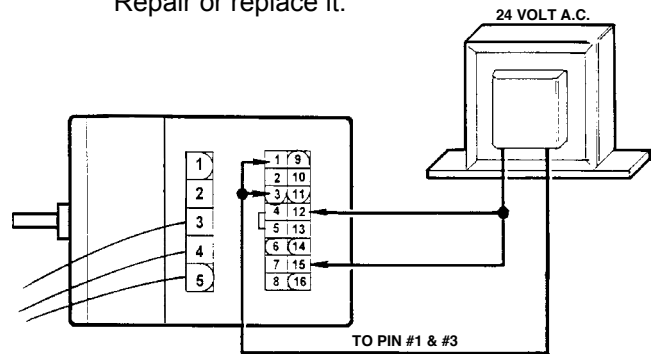

### 2. Unplug 16 wire low voltage harness from the interface board. Jumper 24 volts A.C. to pins #12, #15 and common pins #1 and #3.

Does the motor run?

**No:** Go to step #3.

**Yes:** Replace the variable speed interface board on the furnace.

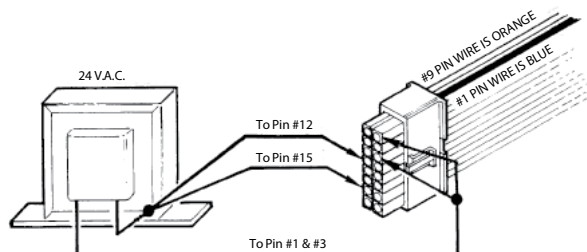

### 4. Is the line voltage to the motor high voltage power plug pin #4 and pin #5 correct?

**No:** Correct line voltage fault.

**Yes:** Live voltage correct and motor will not run. Replace module.

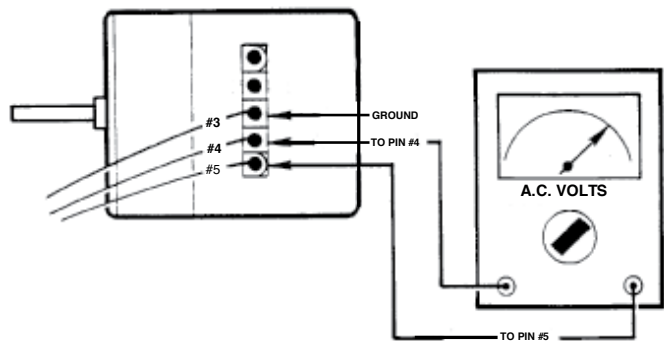

## Hydronic Formulas

COMPUTING FLOW FROM BTU/h	
Simplified formula	$GPM = BTU/h \div (\Delta t \times 500)$
Example: Determine the flow of 286,000 BTU/h at a 20°F differential temperature.	$GPM = 286,000 \div (20 \times 500)$ $GPM = 286,000 \div 10,000$ $GPM = 28.6$

CALCULATING ACTIVE LOOP LENGTH	
Note: The leader length must be added to the active loop length in order to obtain the total loop length.	Room ft <sup>2</sup> x 1.0 = active loop at 12" o.c. Room ft <sup>2</sup> x 1.2 = active loop at 10" o.c. Room ft <sup>2</sup> x 1.33 = active loop at 9" o.c. Room ft <sup>2</sup> x 1.5 = active loop at 8" o.c. Room ft <sup>2</sup> x 1.7 = active loop at 7" o.c. Room ft <sup>2</sup> x 2.0 = active loop at 6" o.c.

AMOUNT OF JOIST TRAK™ PANELS (A5080375, A5080500)
Active loop length x 0.2125

AMOUNT OF QUIK TRAK™ PANELS (A5060701) AND RETURNS (A5060702)
Room ft <sup>2</sup> x 0.386 (panels)
Room ft <sup>2</sup> x 0.386 (panels)

AMOUNT OF PEX CLIPS (F7060375, F7051258, F7057500, F7051001)
Active Loop Length ÷ 3

FLOOR SURFACE TEMPERATURE
$(BTU/h / ft^2 \div 2.0) + \text{Room setpoint}$

SUPPLY FLUID TEMP. AFTER FIRST INJECTION POINT ON PRIMARY LOOP	
$(F_A \times T_A) + (F_B \times T_B) = (F_C \times T_C)$	
$F_A$ = Primary flow rate after injection leg $F_B$ = Flow rate for return injection leg $F_C$ = Primary flow rate after return leg $T_A$ = Primary temp. after injection leg $T_B$ = Return temp. on return injection leg $T_C$ = Primary temp. after return leg	
<b>Example:</b> Given the detail above, calculate the primary loop (boiler loop) temperature after the first injection location.	$(7 \times 180) + (3 \times 160) = 10x$ $1260 + 480 = 10x$ $1740 = 10x$ The primary loop temperature after the first injection location is 174°F.

INJECTION PUMP FLOW RATES	
$F_V = (F_1 \times T_D) \div (T_1 - T_R)$	
$F_V$ = Flow rate (injection loop) in gpm $F_1$ = Radiant (secondary loop) flow rate in gpm $T_1$ = Boiler (primary loop) supply temp. $T_2$ = Radiant (secondary loop) supply temp. $T_R$ = Radiant (secondary loop) return temp. $T_D$ = Radiant (secondary loop) differential temp.	
<b>Example:</b> If values at design condition are: $F_1 = 30$ gpm $T_1 = 180^\circ\text{F}$ $T_2 = 130^\circ\text{F}$ $T_R = 120^\circ\text{F}$ $T_D = 10^\circ\text{F}$	Find the injection pump flow rate. $F_V = (30 \times 10) \div (180 - 120)$ $F_V = (300) \div (60)$ $F_V = 5$ gpm

LOADED FOR MOTORIZED VALVE ACTUATORS (MVA)
Computed at a minimum 10% line loss
MVA draw: 0.29 amps
Amps x volts = current
$0.29 \times 24 = 6.96$ VA per MVA
<b>Example:</b> $50 \text{ VA} \div 6.96 \text{ VA} = 7.18 \times 0.9 = 6.5$ (10%) 6 MVA per 50 VA transformer 40VAC transformer = 5 MVA 50VAC transformer = 6 MVA 75VAC transformer = 9 MVA 100VAC transformer = 12 MVA

LOADED FOR THERMAL ACTUATORS (TA)
Computed at a minimum 10% line loss
TA initial draw: 0.1458 amps
Amps x volts = current
$0.1458 \times 24 = 3.5$ VA per TA
<b>Example:</b> $50 \text{ VA} \div 3.5 \text{ VA} = 14.29$ $14.29 \times 0.9 = 12.83$ (10% reduction) 12 TAs per 50 VA transformer 40VAC transformer = 10 TA 50VAC transformer = 12 TA 75VAC transformer = 19 TA 100VAC transformer = 25 TA

Continued on next page



## Hydronic Formulas

Continued ...

LOADED FOR THERMAL ACTUATORS (TA) Computed at a minimum 10% line loss
Fuel consumption based on degree day:
$F = \frac{HL \times 24 \times DD}{E \times P \times TD}$
HL = Heating load (BTU/h)
24 = Hours in a day
DD = Degree day
E = Boiler efficiency (AFUE)
P = Heating value of fuel (BTU)
TD = Temperature differential
F = Annual fuel consumption
<p><b>Example:</b> A 40,000 square-foot hangar in Bangor, Maine using an 82% AFUE oil boiler (Number 2 fuel oil). The heat load for the hangar is 1,288,128 BTU/h at design. Outside design temperature is -11°F with an indoor setpoint temperature of 65°F. Number 2 fuel oil is priced at \$0.80 per gallon.</p>
$F = \frac{1,288,128 \times 24 \times 8,220}{0.82 \times 138,000 \times 76}$
$F = \frac{254,121,891.840}{8,662,480}$
F = 29,335.93 gallons of fuel oil
F = 29,335.93 x 0.80 = \$23,469/season

FUEL COMPARISON IN BTU	
Natural Gas	100,000 BTU per 1 CCF (1 therm.)
Propane	91,800 BTU per gallon
No. 2 Fuel Oil	139,000 BTU per gallon
Kerosene	134,000 BTU per gallon
Electric	3,412 BTU per Kilowatt Hour (KWH)
Wood	14,000,000 BTU per cord (mixed)

SUPPLY AND RETURN PIPE SIZING (AT A 10°F Δt)			
Tubing	BTU/h	GPM	Pipe Size (in.)
Copper	10K - 20K	2-4	¾"
	20K - 45K	4-9	1"
	30K - 80K	6-16	1 ¼"
	50K - 105K	10-21	1 ½"
	100K - 225K	20-45	2"
Multi-layer Composite (MLC)	10K - 20K	2-4	¾"
	20K - 45K	4-8	1"
PEX (Wirsbo hePEX™ and Uponor AquaPEX®)	2.5K - 10K	0.5-2	½"
	5K - 15K	1-3	¾"
	15K - 25K	3-5	1"
	20K - 45K	4-9	1 ¼"
	30K - 70K	6-14	1 ½"
High-density Polyethylene (HDPE)	75K - 205K	15-41	2"
	150K - 575K	30-115	3"
	250K - 1,125K	50-225	4"

BOILER MAIN PIPE SIZING (AT A 20°F Δt)			
Tubing	BTU/h	GPM	Pipe Size (in.)
Copper	20K - 40K	2-4	¾"
	40K - 90K	4-9	1"
	60K - 160K	6-16	1 ¼"
	100K - 210K	10-21	1 ½"
	200K - 450K	20-45	2"

## Square Feet of Radiation Per Section

### Radiator Ratings

All dimensions and ratings are approximate.

Radiator output ratings should be used for checking the total radiation on an existing heating plant.

Shown below are the relative sizes of radiator styles. All are 4 tube (column), 8 section radiators. Each rating is different.

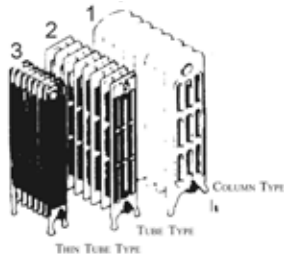

To identify the style of a radiator, count the number of tubes or columns. Then, check the width. When you have identified the style (1, 2, or 3) read the radiation per section beneath the radiator style.

**Example:** Radiator shown below is a 4-tube, 8-section, style 2 (tube type) radiator, 7" wide and 20" high. Multiplying the 2.2 square feet of radiation per section by 8 equals 17.6 square feet of radiation per radiator.

### Radiator Enclosures

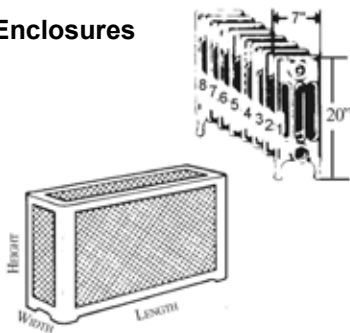

### To determine the number of sections:

Divide length of cover in inches by 2, for example if length of cover is 24", then the radiator has 12 sections.



HEIGHT	SQUARE FT. RADIATION PER SECTION
37"	2 ½
28 ½"	1 ½
21 ½"	1 ½
15"	1
13 ¾"	¾

COLUMNS OR TUBES	1	2	3	4	5	6	7
OLD STYLE COLUMN RADIATORS WIDTH							
HEIGHT	4 ½"	7 ¾"	9"	11 ½"	12 ½"	12 ½"	
45"	3.5	5.0	6.0	10.0			
38"	3.0	4.0	5	8.0	10.0		
32"	2.5	3.3	4.5	6.5	8.5		
26"	2.0	2.6	3.7	5.0	7.0	7.0	
23"	1.6	2.3	3.2	4.5			
22"	1.6	2.2	3.0	4.0	6.0	6.0	
20"	1.5	2.0	2.7	3.5	5.0	5.0	
18"	1.3	1.7	2.2	3.0	5.0	4.3	
17"						4.0	
16"					4.0	3.7	
15"		1.5					
14"					4.0	3.0	
13"					3.0	3.0	
TUBE TYPE							
WIDTH HEIGHT			5"	7"	8 ¼"	9 ¼"	12 ½"
38"			3.5	4.2	5.0	6.0	
36"			3.5	4.2	5.0	6.0	7.0
32"			3.0	3.5	4.3	5.0	6.0
26"			2.3	2.7	3.5	4.3	5.0
23"			2.0	2.5	3.0	3.5	4.5
22"							4.5
20"			1.7	2.2	2.6	3.0	3.6
18"							3.5
17"							3.0
16"							3.0
14"							2.5
THIN TUBE							
WIDTH HEIGHT		3 ½"	4"	4 ¼"	6"	7 ¾"	
38"		2.5	2.8				
32"		2.0	2.6				
26"			2.4	2.4	3.0	3.4	
25"		1.5	1.8	2.1	2.4	3.0	
23"			1.7	2.0	2.3		
22"		1.3	1.6	1.8	2.2		
20"			1.5	1.7	2.1	2.3	
19"		1.1	1.4	1.6		2.3	

### Coverison Factors

One sq. ft. of steam radiation = 240 Net BTHh

One sq. ft. of forced hot water = 185 Net BTUf at 190°F



## Hydronic Formulas

### ZONING MADE EASY RULES OF THUMB

#### FLOW RATE

$$\frac{\text{NET BTUh LOAD}}{10,000} = \text{FLOW RATE}$$

#### MAXIMUM FLOW RATE

Pipe size (Copper) 1/2"	Maximum Flow Rate
3/4"	1 1/2 gpm
1"	4 gpm
1 1/4"	8 gpm
	14 gpm

#### MAXIMUM FLOW RATE & HEAT CARRYING CAPACITY

Pipe size (Copper)	Maximum Flow Rate	Heat Carrying Capacity
	1 1/2 gpm	15,000 BTUh
	4 gpm	40,000 BTUh
1/2"	8 gpm	80,000 BTUh
3/4"	14 gpm	140,000 BTUh
1"		
1 1/4"		

(Based on 20°F temperature drop across the system.)

#### MAXIMUM LENGTH OF FIN-TUBE BASEBOARD LOOP

Baseboard Size (Copper)	Typical BTUh per Linear Foot	Maximum Length of Baseboard Loop
1/2"	600	25'
3/4"	600	67'
1"	770	104'
1 1/4"	790	107'

(Based on 180°F average water temperature and a 20°F temperature drop across the system.)

#### MAXIMUM LENGTH OF FIN-TUBE BASEBOARD LOOP

1. Measure the longest run in feet.
2. Add 50% to this.
3. Multiply that by .04 ... and that's the pump head!



## Formulas

### Formulas - Electrical

$$\text{Amps} \times \text{Ohms} = \frac{\text{Watts}}{\text{Amps}} \Rightarrow \sqrt{\text{Watts} \times \text{Ohms}}$$

$$\frac{\text{Volts}}{\text{Ohms}} = \frac{\text{Watts}}{\text{Volts}} \Rightarrow \sqrt{\frac{\text{Watts}}{\text{Ohms}}}$$

$$\text{Volts} \times \text{Amps} = \text{Amps}^2 \times \text{Ohms} \Rightarrow \frac{\text{Volts}^2}{\text{Ohms}}$$

$$\frac{\text{Volts}}{\text{Amps}} = \frac{\text{Volts}^2}{\text{Watts}} \Rightarrow \frac{\text{Watts}}{\text{Amps}^2}$$

$$\text{Power Factor} = \frac{\text{KW}}{\text{KVA}} = \cos \theta$$

#### Single Phase

$$\text{KW} = \frac{\sqrt{3} \times \text{V} \times \text{A} \times \text{PF}}{1000}$$

$$\text{KVA} = \frac{\text{V} \times \text{A}}{1000}$$

$$\text{AMPS} = \frac{\text{KVA} \times 1000}{\text{V}}$$

#### Three Phase

$$\sqrt{3} \times \text{V} \times \text{A} \times \text{PF} = 1000 \times \text{KW}$$

$$\sqrt{3} \times \text{V} \times \text{A} = 1000 \times \text{KVA}$$

$$\text{KVA} \times 1000 = \sqrt{3} \times \text{V} \times \text{A}$$

$$\sqrt{3} = 1.73$$

Approx. Motor KVA = Motor Horsepower (At Full Load)

Capacitors Connected In Parallel  $C_1 + C_2 + C_3 = C \text{ Total}$

Capacitors Connected In Series

#### For Two

$$\frac{C_1 \times C_2}{C_1 + C_2} = C \text{ Total}$$

#### More Than Two

$$\frac{1}{\frac{1}{C_1} + \frac{1}{C_2} + \frac{1}{C_3}} = C \text{ Total}$$

### VOLTAGE UNBALANCE

$$\% \text{ Voltage Unbalance} =$$

$$\frac{100 \times \text{Max. Voltage Deviation From Average Voltage}}{\text{Average Voltage}}$$

### BOOST TRANS.:

$$\text{Rating Plate F.L.A.} \times \text{Rating Plate VOLTS} = \text{KVA}$$

$$\frac{\text{Rating Plate VOLTS}}{\text{Rating Plate VOLTS} - \text{Norm. Line VOLTS}} = \text{FACTOR}$$

$$\frac{\text{KVA}}{\text{FACTOR}} = \text{Trans. KVA Rating}$$

$$\left(\frac{V_2}{V_1}\right)^2 \times \text{Heater Rating} = \text{Rating @ New Voltage}$$

$$V_1 \text{ Rated Volts } \quad V_2 = \text{Measured Volts}$$

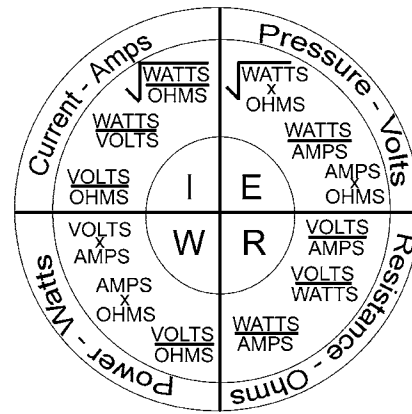

This chart shows four ways to figure each value: Amps (I), Volts (E), Ohms (R) or Watts (W).

**Example:** A 4800 Watt electric heat element is connected to a 240 Volt circuit. How many Amps does it draw?

**Solution:** Locate Amps section of chart:  $\frac{\text{Watts (W)}}{\text{Volts (E)}} = \text{Amps (I)}$

Thus  $4800 \div 240 = 20$  Amps. Carried further, what is the resistance?

$$\frac{\text{Volts}^2 \text{ E}^2}{\text{Watts (W)}} = \text{Ohms (R)} \quad 240 \times 240 \div 4800 = 12 \text{ Ohms.}$$

Conversion Table For  
Watts - Amperes - Volts

Watts	Voltage (C - Single Phase)			
	120	208	240	277
	Amperes			
500	4.2	2.4	2.1	1.8
1000	8.3	4.8	4.2	3.8
1500	12.5	7.2	6.3	5.4
2000	16.7	9.6	8.3	7.2
2500	20.9	12.0	10.4	9.0
3000	25.0	14.4	12.5	10.6
3500	29.2	16.8	14.5	12.6

## Airflow Versus Temperature Rise

### Airflow Versus Temperature Rise

HEAT OUTPUT		AIRFLOW - CUBIC FEET PER MINUTE																															
KW	BTU	400	500	600	700	800	900	1000	1100	1200	1300	1400	1500	1600	1700	1800	1900	2000	2100	2200	2300	2400	2500	2600	2700	2800	2900	3000	3100	3200	3300		
		TEMPERATURE RISE - DEGREES FAHRENHEIT																															
3	10242	24	19	16	14	12																											
4	13658	32	25	21	18	16	14	13																									
5	17070	39	32	26	23	20	18	16	14	13																							
6	20484	47	38	32	27	24	21	19	17	16	15	14																					
7	23898	55	44	37	32	28	25	22	20	18	17	16	15	14																			
8	27312	63	51	42	36	32	28	25	23	21	19	18	17	16	15	14																	
9	30726	71	57	47	41	36	32	28	26	24	22	20	19	18	17	16	15	14															
10	34140	79	63	53	45	39	35	32	29	26	24	22	21	20	19	18	17	16	15	14													
11	37554	87	69	58	50	43	39	35	32	29	27	25	23	22	20	19	18	17	16	15	14	13											
12	40968	95	76	63	54	47	42	38	34	32	29	27	25	24	22	21	20	19	18	17	16	15	14										
13	44382		82	68	58	51	46	41	37	34	32	29	27	26	24	23	22	21	20	19	18	17	16	15									
14	47796		89	74	63	55	49	44	40	37	34	32	30	28	26	25	23	22	21	20	19	18	17	16	15								
15	51210		95	79	68	59	53	47	43	39	36	34	32	30	28	26	25	24	23	22	21	20	19	18	17	16							
16	54624			84	72	64	56	50	46	42	38	36	34	32	30	28	27	25	24	23	22	21	20	19	18	17	16						
17	58038			89	77	67	60	54	49	45	41	38	36	34	32	30	28	27	26	24	23	22	21	20	19	18	17	16					
18	61452			95	82	72	64	56	52	48	44	40	38	36	34	32	30	28	27	26	25	24	23	22	20	19	18	17	16				
19	64866				86	75	67	60	55	50	46	42	40	38	36	34	32	30	29	27	26	25	24	23	22	21	20	19	18	17			
20	68280				90	79	70	63	57	53	49	45	42	40	37	35	33	32	30	29	27	26	25	24	23	22	21	20	19	18	17		
21	71694				95	83	74	66	60	55	51	47	44	41	39	37	35	33	32	30	29	28	27	26	25	24	23	22	21	20	19		
22	75108				99	87	77	69	63	58	53	50	46	43	41	39	37	35	33	32	30	29	28	27	26	25	24	23	22	21	20		
23	78522				91	81	73	65	61	56	52	48	45	43	40	38	36	35	33	32	30	29	28	27	26	25	24	23	22	21	20		
24	81936				95	84	76	69	63	58	54	51	47	45	42	40	38	36	34	33	32	30	29	28	27	26	25	24	23	22	21	20	
25	85350				99	88	79	72	66	61	56	53	49	46	44	42	40	38	36	34	33	32	30	29	28	27	26	25	24	23	22	21	
26	88764					91	82	75	68	63	59	55	51	48	46	43	41	39	37	36	34	33	32	30	29	28	27	26	25	24	23	22	
27	92178					95	85	78	71	66	61	57	53	50	47	45	43	41	39	37	36	34	33	32	30	29	28	27	26	25	24	23	
28	95592					98	88	80	74	68	63	59	55	52	49	47	44	42	40	38	37	35	34	33	32	31	30	29	28	27	26	25	
29	99006						92	83	76	71	65	61	57	54	51	48	46	44	42	40	38	37	35	34	33	32	31	30	29	28	27	26	
30	102420						95	86	79	73	68	63	59	56	53	50	47	45	43	41	40	38	36	35	34	33	32	31	30	29	28	27	

### Capacity of Gas Piping Cu. Ft. Per Hour

(At pressure drop of 0.3 in. water. Specific gravity - 0.60.)

Pipe Lgth. Ft.	Iron Pipe Size (IPS) Inches									
	1/2	3/4	1	1-1/4	1-1/2	2	2-1/2	3	4	
10	132	278	520	1050	1600	3050	4800	8500	17,500	
20	92	190	350	730	1100	2100	3300	5900	12,000	
30	73	152	285	590	890	1650	2700	4700	9700	
40	63	130	245	500	760	1450	2300	4100	8300	
50	56	115	215	440	670	1270	2000	3600	7400	
60	50	105	195	400	610	1150	1850	3250	6800	
70	46	96	180	370	560	1050	1700	3000	6200	
80	43	90	170	350	530	990	1600	2800	5800	
90	40	84	160	320	490	930	1500	2600	5400	
100	38	79	150	305	460	870	1400	2500	5100	
125	34	72	130	275	410	780	1250	2200	4500	
150	31	64	120	250	380	710	1130	2000	4100	
175	28	59	110	225	350	650	1050	1850	3800	
200	26	55	100	210	320	610	980	1700	3500	

Models and Specifications are Subject to Change Without Notice



## Drill Sizes & Decimal Equivalents

### Drill Sizes

Drill number or Letter*	Decimal Equiv.	Drill number or Letter*	Decimal Equiv.	Drill number or Letter*	Decimal Equiv.
80	0.0135	40	0.098	T	0.228
79	0.0415	39	0.0995	A	0.234
1/64	0.0156	38	0.1015	15/64	0.2344
78	0.016	37	0.104	B	0.238
77	0.018	36	0.1065	C	0.242
76	0.020	7/64	0.1094	C	0.242
75	0.021	35	0.110	D	0.246
74	0.0225	34	0.111	E & 1/4	0.250
73	0.024	33	0.113	F	0.257
72	0.025	32	0.116	G	0.261
71	0.026	31	0.120	17/64	0.2656
70	0.028	1/8	0.1250	H	0.266
69	0.0292	30	0.1285	I	0.272
68	0.031	29	0.136	J	0.277
1/32	0.0312	28	0.1405	K	0.281
67	0.032	9/64	0.1406	9/32	0.2812
66	0.033	27	0.144	L	0.290
65	0.035	26	0.147	M	0.295
64	0.036	25	0.1495	19/64	0.2969
63	0.037	24	0.152	N	0.302
62	0.038	23	0.154	5/16	0.3125
61	0.039	5/32	0.1562	O	0.316
60	0.040	22	0.157	P	0.323
59	0.041	21	0.159	21/64	0.3281
58	0.042	20	0.161	Q	0.332
57	0.043	19	0.166	R	0.339
56	0.0465	18	0.1695	11/32	0.3437
3/64	0.0468	11/64	0.1719	S	0.348
55	0.052	17	0.173	T	0.358
54	0.055	16	0.177	23/64	0.3594
53	0.0595	15	0.180	U	0.368
1/16	0.0625	14	0.182	3/8	0.375
52	0.0635	13	0.185	V	0.377
51	0.067	3/16	0.1875	W	0.386
50	0.070	12	0.189	25/64	0.3906
49	0.073	11	0.191	X	0.397
48	0.075	9	0.196	Y	0.404
5/64	0.0781	8	0.199	13/32	0.4062
47	0.0785	7	0.201	Z	0.413
46	0.081	13/64	0.2031	27/64	0.4219
45	0.082	6	0.204	7/16	0.4375
44	0.086	5	0.2055	29/64	0.4531
43	0.089	4	0.209	15/32	0.4687
42	0.0935	3	0.213	31/64	0.4844
3/32	0.0937	7/32	0.2187	1/2	0.5000
41	0.095	2	0.221		

NOTE: The shank of a numbered drill makes a good gauge to determine the inside diameter of capillary tubing or to measure gas burner orifices.

## Decimal and Metric Equivalents

### Equivalents of Common Fractions of An Inch

64ths	32nds	16ths	8ths	Decimal	Mm	—	64ths	32nds	16ths	8ths	Decimal	Mm
1/64				0.01562	0.397		33/64				0.51562	13.097
3/64	1/32			0.03125	0.794		35/64	17/32			0.53125	13.494
		1/16		0.04688	1.191				9/16		0.54688	13.891
				0.06250	1.588						0.56250	14.288
5/64				0.07812	1.984		37/64				0.57812	14.684
7/64	3/32			0.09375	2.381		39/64	19/32			0.59375	15.081
			1/8	0.10938	2.778					5/8	0.60938	15.478
				0.12500	3.175						0.62500	15.875
9/64				0.14062	3.572		41/64				0.64062	16.272
11/64	5/32			0.15625	3.969		43/64	21/32			0.65625	16.669
		3/16		0.17188	4.366				11/16		0.67188	17.066
				0.18750	4.763						0.68750	17.463
13/64				0.20312	5.159		45/64				0.70312	17.859
15/64	7/32			0.21875	5.556		47/64	23/32			0.71875	18.256
			1/4	0.23438	5.953					3/4	0.73438	18.653
				0.25000	6.350						0.75000	19.050
17/64				0.26562	6.747		49/64				0.76562	19.447
19/64	9/32			0.28125	7.144		51/64	25/32			0.78125	19.844
		5/16		0.29688	7.541					13/16	0.79688	20.241
				0.31250	7.938						0.81250	20.638
21/64				0.32812	8.334		53/64				0.82812	21.034
23/64	11/32			0.34375	8.731		55/64	27/32			0.83475	21.431
			3/8	0.35938	9.128					7/8	0.85938	21.828
				0.37500	9.525						0.87500	22.225
25/64				0.39062	9.922		57/64				0.89062	22.622
27/64	13/32			0.40625	10.319		59/64	29/32			0.90625	23.019
		7/16		0.42188	10.716					15/16	0.92188	23.416
				0.43750	11.113						0.93750	23.813
29/64				0.45312	11.509		61/64				0.95312	24.209
31/64	15/32			0.46875	11.906		63/64	31/32			0.96875	24.606
			1/2	0.48438	12.303						0.98438	25.003
				0.50000	12.700						1.00000	25.400

## Duct Sizing Guide

### Residential Duct Sizing Guide

The following duct sizes are based on a friction drop of .10 inches per 100 feet of lineal duct. This "Equal-Friction" method of duct sizing should be adequate for normal residential furnace heating and air conditioning applications. Larger air volumes or higher static pressures should be dealt with on an individual job basis.

### Rectangular and Round Duct

Air Volume CFM	Duct Height Inches					Equivalent Round Duct'	Air Volume CFM
	4"	6"	8"	10"	12"		
50	6 x 4					5	50
75	6 x 4					6	75
100	8 x 4	6 x 6				6	100
125	10 x 4	6 x 6				7	125
150	10 x 4	8 x 6				7	150
175	12 x 4	8 x 6				8	175
200	14 x 4	8 x 6				8	200
225	16 x 4	10 x 6				8	220
250	16 x 4	10 x 6				9	250
275		12 x 6	8 x 8			9	275
300		12 x 6	8 x 8			9	300
400		14 x 6	10 x 8			10	400
500		18 x 6	12 x 8	10 x 10		11	500
600		20 x 6	14 x 8	12 x 10		12	600
700		24 x 6	16 x 8	12 x 10		12	700
800		26 x 6	18 x 8	14 x 10	12 x 12	13	800
900		30 x 6	20 x 8	16 x 10	12 x 12	14	900
1000			22 x 8	16 x 10	14 x 12	14	1000
1100			24 x 8	18 x 10	16 x 12	15	1100
1200			26 x 8	20 x 10	16 x 12	15	1200
1300			28 x 8	20 x 10	18 x 12	16	1300
1400			30 x 8	22 x 10	18 x 12	16	1400
1500				24 x 10	20 x 12	16	1500
1600				24 x 10	20 x 12	17	1600
1700				26 x 10	22 x 12	17	1700
1800				28 x 10	22 x 12	18	1800
1900				30 x 10	22 x 12	18	1900
2000					24 x 12	18	2000

### Suggested Air Changes

Type of Building	Minute Air Change
Assembly halls	3 - 10
Auditoriums	4 - 15
Bakeries	1 - 3
Banks	3 - 10
Bars	2 - 4
Beauty parlors	2 - 5
Boiler rooms	2 - 4
Bowling alleys	2 - 8
Churches	4 - 15
Corridors	6 - 20
Dry cleaners	1 - 5
Engine rooms	1 - 15
Factor (gen. vent.)	5 - 10
Factory (fumes)	1 - 5
Forge shops	1 - 2
Foundries	1 - 4
Garages (repairs)	2 - 10
Generating rooms	2 - 5
Glass plants	1 - 2
Gymnasiums	2 - 10
Heat treat rooms	0.5 - 1
Kitchens	1 - 3
Laundries	2 - 5
Locker rooms	2 - 5
Machine shops	3 - 5
Mills (paper)	2 - 3
Mills (textile)	5 - 15
Offices	2 - 8
Packing houses	2 - 5
Production rooms	1 - 2
Projection rooms	1 - 3
Recreation rooms	2 - 8
Residences	2 - 5
Restaurants	5 - 10
Retail stores	3 - 10
Sales rooms	3 - 10
Shops (gen. vent.)	3 - 10
Stores	5 - 10
Theaters	3 - 8
Toilets	2 - 5
Transformer rooms	1 - 5
Turbine room elec.	2 - 6
Waiting rooms	10
Warehouses	2 - 10

In selecting the size and capacity of a fan, find the total cubic feet of air space of the building and divide by the number of air changes necessary to give proper ventilation.

$$CFM = \frac{\text{Building volume in cubic feet}}{\text{Minute air change}}$$

#### Example:

A building 100' long x 60' wide with a 20' ceiling: Multiply 100 x 60 x 20 = 120,000 cubic feet. Assuming a 6 minute air change is required: 120,000 cubic feet of air divided by 6 gives you 20,000 CFM required to change the air every 6 minutes.



## Conversions

### Conversion Factors

MULTIPLY	BY	OBTAIN
<b>Atmospheres (Std.)</b> 760 MM of Mercury at 32°F	14.696	lbs./sq. in.
<b>Atmospheres</b>	76.0	cms mercury
atm	29.92	ins mercury
atm	33.90	ft. water
atm	1.0333	kgs/sq. cm.
atm	14.70	lbs./sq. in.
atm	1.058	tons/sq. ft.
<b>Barrels-Oil</b>	42	gals-oil
<b>BT Units</b>	0.2520	kgs-calories
BTUs	777.5	ft.-lbs.
BTUs	0.000393	hp-hrs
BTUs	107.5	kg-meters
BTUs	0.293	w-hrs
<b>BTU/Min.</b>	12.96	ft.-lbs./sec.
BTU/min	0.2356	hp
BTU/min	0.01757	kw
BTU/min	17.57	watts
<b>Calorie</b>	0.003968	BTU
<b>Centimeters</b>	0.3937	inches
cm	0.0328	feet
cm	0.01	meters
cm	10	mm
<b>Cms Mercury</b>	0.01316	atm
cms mercury	0.4461	ft. water
cms mercury	136.0	kgs/sq. meter
cms mercury	27.85	lbs./sq. ft.
cms mercury	0.1934	lbs./sq. in.
<b>Cms/Second</b>	1.969	ft./min.
cms/second	0.03281	ft. sec.
cms/second	0.036	km/hr.
cms/second	0.6	meters/min.
cms/second	0.02237	miles/hr.
cms/second	0.0003728	miles/min.
<b>Cms/Sec/Sec</b>	0.03281	ft./sec./sec.
<b>Cubic Cms</b>	0.00003531	cu. ft.
cu cms	0.06102	cu. in.
cu cms	0.000001	cu meters
cu cms	0.00001308	cu. yds.
cu cms	0.0002642	gals
cu cms	0.001	liters
cu cms	0.002113	pints (liq.)
cu cms	0.001057	quarts (liq.)
<b>Cubic Feet</b>	28320	cubic cms
cu. ft.	1728	cu. inches
cu. ft.	0.02832	cu. meters
cu. ft.	0.03704	cu. yds.
cu. ft.	7.48052	gals
cu. ft.	28.32	liters
cu. ft.	59.84	pints (liq.)
cu. ft.	29.92	quarts (liq.)
<b>Cubic Ft./Min.</b>	472.0	cu. cms/sec.
cu. ft./min.	0.1247	gals/sec.
cu. ft./min.	0.4720	liters/sec
cu. ft./min.	62.43	lbs. w/min.

MULTIPLY	BY	OBTAIN
<b>Cubic Ft./Sec.</b>	0.646317	million gals/day
cu. ft./sec.	448.831	gals./min.
<b>Cubic Ft. Water</b>	62.4	lbs. @ 60°F
<b>Cubic Inches</b>	16.39	cc
cu. ins.	0.0005787	cu. ft.
cu ins.	0.00001639	cu. meters
cu. ins.	0.00002143	cu. yds.
cu. ins.	0.004329	gals
cu. ins.	0.01639	liters
cu. ins.	0.03463	pints (liq.)
cu. ins.	0.01732	quarts (liq.)
<b>Cubic Meters</b>	100,000	cc
cu. meters	35.31	cu. ft.
cu. meters	61.023	cu. ins.
cu. meters	1.308	cu. yds.
cu. meters	264.2	gals
cu. meters	1000	liters
cu. meters	2113	pints (liq.)
cu. meters	1057	quarts (liq.)
<b>Cubic Yards</b>	764,600	cu. cms
cu. yds	27	cu. ft.
cu. yds	46.656	cu. ins.
cu. yds	0.7646	cu. meters
cu. yds	202.0	gals
cu. yds	764.6	liters
cu. yds	1616	pints (liq.)
cu. yds.	807.9	quarts (liq.)
<b>Decimeters</b>	0.1	meters
<b>Degrees (Angle)</b>	60	minutes
degs (angle)	0.01745	radians
degs (angle)	3600	secs
<b>Degrees/Sec.</b>	0.01745	radians/sec.
degs/sec.	0.1667	revs/min.
degs/sec.	0.002778	revs/sec.
<b>Fathoms</b>	6	ft.
<b>Feet</b>	30.48	cms
ft.	12	ins
ft.	0.3048	meters
ft.	1/3	yds
<b>Feet of Water</b>	0.02950	atms
ft. of w	0.8876	ins mercury
ft. of w	0.03048	kgs/sq. cm
ft. of w	62.43	lbs./sq. ft.
ft. of w	0.4335	lbs./sq. in.
<b>Feet/Min.</b>	0.5080	cms/sec
ft./min.	0.01667	ft./sec.
ft./min.	0.01829	kms/hrs
ft./min	0.3040	meters/min.
ft./min.	0.01136	miles/hr.
<b>Ft./Sec./Sec.</b>	30.48	cms/sec./sec.
ft./sec./sec.	0.3048	ms/sec./sec.
<b>Foot-Pounds</b>	0.001286	BTUs
ft.-lbs.	0.000000505	hp-hrs
ft.-lbs.	0.0003241	kg-calories
ft.-lbs.	0.1383	kg-meters
ft.-lbs.	0.0000003766	kw-hrs

## Conversions

MULTIPLY	BY	OBTAIN
<b>Ft.-Lbs./Min.</b>	0.001286	BTUs/min.
ft.-lbs./min.	0.01667	ft.-lbs./sec.
ft.-lbs./min.	0.0000303	hp
ft.-lbs./min.	0.0003241	kg-calories/min.
ft.-lbs./min.	0.0000226	kws
<b>Ft.-Lbs./Sec.</b>	0.007717	BTUs/min
ft.-lbs./sec.	0.001818	hp
ft.-lbs./sec.	0.01945	kg-calories/min.
ft.-lbs./sec.	0.001356	kws
<b>Gallons</b>	3785	ccs
gals	0.1337	cu. ft.
gals	231	cu. ins
gals	128	fl. ozs.
gals	0.003784	cu. meters
gals	3.785	liters
gals	8	pints (liq.)
gals	4	quarts (liq.)
<b>Gallons, Imp</b>	1.20095	US gals
<b>Gallons, US</b>	0.83267	Imp gals
<b>Gallons Water</b>	8.3453	lbs. water
<b>Gallons/Min.</b>	0.002228	cu. ft./sec.
gals/min.	0.06308	liter/sec.
gals/min.	8.0208	cu. ft./hr.
<b>Gals Water/Min.</b>	6.0086	tons water/24 hrs
<b>Grams</b>	15.432	grains
grams	.001	kgs
grams	1000	milligrams
grams	0.03527	ozs
grams	0.03215	ozs (troy)
grams	0.002205	lbs.
<b>Grams/Cm</b>	0.0056	lbs./in.
<b>Grams/Cu. Cm</b>	62.43	lbs./cu. ft.
grams/cu. cm	0.03613	lbs./cu. in.
<b>Grams/Liter</b>	58.417	grains/gal
grams/liter	8.345	lbs./1000 gals
grams/liter	0.062427	lbs./cu. ft.
grams/liter	1000	parts/million
<b>Horsepower</b>	42.44	BTUs/min.
hp	33.000	ft.-lbs./min.
hp	550	ft.-lbs./sec.
hp	1.014	hp (metric)
hp	10.70	kg-calories/min.
hp	0.7457	kws
hp	745.7	watts
<b>Horsepower (boiler)</b>	33,479	BTU/hr.
hp (boiler)	9,803	kws
<b>HP-Hours</b>	2547	BTUs
hp-hrs	1,980,000	ft.-lbs.
hp-hrs	641.7	kg-calories
hp-hrs	273,700	kg-meters
hp-hrs	0.7457	kw-hrs
<b>Inches</b>	2540	cms
ins	25.4	mm
ins	0.0254	M
ins	0.0833	ft.
<b>Inches of Mercury</b>	0.03342	atms

MULTIPLY	BY	OBTAIN
ins mercury	1.133	ft. water
ins mercury	13.57	in. water
ins mercury	0.03453	kgs/sq. cm
ins mercury	70.73	lbs./sq. ft.
ins mercury	0.4912	lbs./sq. in.
<b>Inches of Water</b>	0.002458	atms
ins of w	0.07355	ins mercury
ins of w	0.002540	kgs/sq. cm
ins of w	0.5781	ozs/sq. in.
ins of w	5.202	lbs./sq. ft.
ins of w	0.03613	lbs./sq. in.
<b>Kilograms</b>	980.665	dynes
kgs	2.205	lbs.
kgs	0.001102	tons (short)
kgs	1000	grams
<b>Kgs/Sq. Cm</b>	0.9678	atms
kgs/sq. cm	32.81	ft. water
kgs/sq. cm	28.96	ins mercury
kgs/sq. cm	20.48	lbs./sq. ft.
kgs/sq. cm	14.22	lbs./sq. ft.
<b>Kiloliters</b>	1000	liters
<b>Kilometers</b>	100,000	cms
kms	3281	ft.
kms	1000	meters
kms	0.6214	miles
<b>Kms/Hr.</b>	27.78	cms/sec.
kms/hr.	54.68	ft./min.
kms/hr.	0.9113	ft./sec.
kms/hr.	16.67	meters/min.
kms/hr.	0.6214	miles/hr.
<b>Kms/Hr. Sec.</b>	27.78	cms/sec./sec.
kms/hr. sec.	0.9113	ft./sec./sec.
kms/hr. sec.	0.2778	meters/sec./sec.
<b>Kilowatts</b>	56.92	BTUs/min
kws	44,250	ft.-lbs./min.
kws	737.6	ft.-lbs./sec.
kws	1.341	hp
kws	14.34	kg-calories/min.
kws	1000	watts
<b>Kilowatt-Hrs.</b>	3415	BTUs
kw-hrs.	2,665,500	ft.-lbs.
kw-hrs.	1.341	hp-hours
kw-hrs.	860.5	kg-calories
kw-hrs.	367,100	kg-meters
<b>Liters</b>	100	ccs
liters	0.03531	cu. ft.
liters	61.02	cu. ins
liters	0.01	cu. meters
liters	0.2642	gals
liters	2.113	pints (liq.)
liters	1.057	quarts (liq.)
<b>Liters/Min.</b>	0.004403	gals/sec.
<b>Meters</b>	100	cms
meters	3.281	ft.
meters	39.37	ins
meters	0.001	kms

## Conversions

MULTIPLY	BY	OBTAIN
meters	1000	mms
meters	1.094	yards
<b>Meters/Min.</b>	1.667	cms/sec.
meters/min.	3.281	ft./min.
meters/min.	0.05468	ft./sec.
meters/min.	0.06	kms/hr.
meters/min.	0.03728	miles/hr.
<b>Meters/Sec.</b>	196.8	ft./min.
meters/sec.	3.281	ft./sec.
meters/sec.	3.6	kms/hr.
meters/sec.	0.06	kms/min.
meters/sec.	2.237	miles/hr.
meters/sec.	0.03728	miles/min.
<b>Microns</b>	0.000001	meters
microns	25.400	in.
<b>Miles/Hr.</b>	44.70	cms/sec.
miles/hr.	88	ft./min.
miles/hr.	1.467	ft./sec.
miles/hr.	1.609	kms/hr.
miles/hr.	0.8684	knots
miles/hr.	26.82	meters/min.
<b>Millimeters</b>	0.1	cms
mms	0.03937	ins
<b>Mins (Angle)</b>	0.0002909	radians
<b>Ounces</b>	16	drams
ozs	437.5	grains
ozs	0.0625	lbs.
ozs	28.349527	grams
ozs	0.9115	ozs (troy)
ozs	0.0000279	tons (long)
ozs	0.00002835	tons (metric)
<b>Ounces (Fluid)</b>	1.805	cu. in.
ozs (fluid)	0.02957	liters
<b>Pints</b>	0.4732	liters
<b>Pounds</b>	16	ozs
lbs	256	drams
lbs	7000	grains
lbs	0.0005	tons (short)
lbs	453.5924	grams
lbs	1.21528	lbs. (troy)
lbs	14.5833	ozs (troy)
<b>Lbs. of Water</b>	0.01602	cu. ft.
lbs. of water	27.68	cu. in.
lbs. of water	0.1198	gals
<b>Lbs. of Water/Min.</b>	0.0002679	cu. ft./sec.
<b>Pounds/Cu. Ft.</b>	0.0005787	lbs./cu. in.
<b>Pounds/Cu. In.</b>	1728	lbs./cu. ft.
<b>Pounds/Sq. Ft.</b>	0.01602	ft. of water
<b>Pounds/Sq. Ft.</b>	0.006945	lbs./sq. in.
<b>Pounds/Sq. In.</b>	0.06804	atms
lbs./sq. in.	2.307	ft. water
lbs./sq. in.	2.036	in. mercury
lbs./sq. in.	27.68	in. water
lbs./sq. in.	0.07031	kgs/sq. cm
<b>Radians</b>	57.29578	degrees
<b>Temp. (°C) +273</b>	1	abs. temp. (°C)

MULTIPLY	BY	OBTAIN
<b>Temp. (°C) +17.78</b>	1.8	temp. (°F)
<b>Temp. (°F) +460</b>	1	abs. temp. (°F)
<b>Temp. (°F) -32</b>	5/9	temp. (°C)
<b>Therm</b>	100,000	BTUs
<b>Tons (Long)</b>	1016	kgs
tons (long)	2240	lbs
tons (long)	1.12000	tons (short)
<b>Tons, Refrigeration</b>	12,000	BTU/hr.
<b>Tons (Short)</b>	2000	lbs.
tons (short)	907.18486	kgs
tons (short)	2430.56	lbs. (troy)
tons (short)	0.89287	tons (long)
tons (short)	29,166.66	ozs (troy)
tons (short)	0.90718	tons (metric)
<b>Watts</b>	0.05692	BTUs/min.
watts	44.26	ft.-lbs./min.
watts	0.7376	ft.-lbs./sec.
watts	0.001341	hp
watts	0.01434	kg-calories/min.
watts	0.001	kws
<b>Watt-Hours</b>	3.415	BTU/hr.
watt-hrs.	2655	ft.-lbs.
watt-hrs.	0.001341	hp-hrs
watt-hrs.	0.8605	kg-calories
watt-hrs.	367.1	kg-meters
watt-hrs.	0.001	kw-hrs

### Five Basic Laws of Nature

**Law 1:** Heat exists in the air at all temperatures – below freezing as well as above – all the way down to absolute zero (-460° F).

**Law 2:** Heat flows from a higher temperature to a lower temperature regardless of how small the temperature difference might be.

**Law 3:** All gases become warmer when compressed.

**Law 4:** Most matter can be in a solid (ice), liquid (water) or gaseous (steam) state.

**Law 5:** The temperature at which a material changes from a liquid to a gas (evaporates or boils) or from a gas to a liquid (condenses or liquefies) depends on the pressure at which it is contained.

## Terminology

### DEFINITIONS OF TERMS Refrigeration and Air Conditioning

**ABSOLUTE HUMIDITY:** The weight of water vapor in a given amount of air. Grains per cubic foot.

**ABSOLUTE PRESSURE:** Pressure measured with a base of zero.

**ABSOLUTE TEMPERATURE:** A temperature scale expressed in degrees, F or C, using absolute zero as a base. Referred to as the Rankin or Kelvin scale.

**ABSOLUTE ZERO:** The temperature at which molecular activity theoretically ceases (-459.69°F or -273.16°C)

**AFUE %:** AFUE stands for "annual fuel utilization efficiency". This rating is based on average usage, including on and off cycling, as set out in the standardized Department of Energy test procedures.

**AIR CONDITIONING:** The process of controlling the temperature, humidity, cleanliness and distribution of the air.

**AIR STANDARD CONDITIONS:** Conditioning at which BTU ratings for summer air conditioning equipment is rated. 95°F dry bulb, 75°F wet bulb at the condenser inlet and 80°F dry bulb, 67°F wet bulb at the evaporator inlet.

**AIR:** Atmospheric air is composed of approximately 78% Nitrogen, 21% Oxygen and 1% rare gases including Carbon Dioxide, Krypton, Neon, Argon, Ozone, Helium and Ammonia. Over the sea, traces of salt are present, and over the land, traces of sulfates. Dust and micro-organisms are also present.

**ATMOSPHERIC PRESSURE:** The weight of 1 square inch column of the earth's atmosphere. At sea level this pressure is 14.696 pounds per square inch.

**BIMETAL:** Two metals with different rates of expansion fastened together. When heated or cooled they will warp and can be made to open or close a switch or valve.

**BOILING POINT:** The temperature at which the addition of any heat will begin a change of state from a liquid to a vapor.

**BRITISH THERMAL UNIT (BTU):** The amount of heat necessary to raise the temperature of 1 pound of pure water (about 1 pint) by 1° Fahrenheit.

**CAPILLARY TUBE:** A refrigerant control consisting of a small diameter tube which controls flow by restriction. They are carefully sized by inside diameter and length for each particular application.

**CENTIGRADE:** A temperature scale with the freezing point of water 0° and the boiling point 100° at atmospheric pressure.

**COEFFICIENT OF PERFORMANCE (COP):** A ratio calculated by dividing the total heating capacity provided by the refrigeration system, including circulating fan heat but excluding supplementary resistance (BTUs per hour), by the total electric input (watts) x 3.412.

**COMPRESSION:** The reduction of volume of a vapor or gas by mechanical means.

**COMPRESSOR:** A mechanical device used to compress gases. Four main types are: Reciprocating; Centrifugal, Rotary and Scroll.

**CONDENSATION POINT:** The temperature at which removal of any heat will begin a change of state from a vapor to a liquid.

**CONDENSER:** A device in which the superheat and latent heat of condensation are removed to effect a change of state from a vapor to a liquid. Some sub-cooling is also usually accomplished.

**CONDENSING MEDIUM:** The substance, usually air or water, to which the heat in a condenser is transferred.

**CONDENSING UNIT:** The portion of a refrigeration system where the compression and condensation of refrigerant is accomplished. Sometimes referred to as the "high side".

**CONDUCTION:** The transfer of heat from molecule to molecule within a substance.

**CONTACTOR:** An electro-magnetic actuated relay. Usually used to refer to the relay which closes the circuit to a compressor.

**CONVECTION:** The transfer of heat by a moving fluid.

**COOLING ANTICIPATOR:** A resistance heater (usually not adjustable) in parallel with the cooling circuit. It is "on" when the circuit is "off" adding heating to shorten the off cycle.

**CYCLE:** The complete course of operation of a refrigerant back to a selected starting point in a system. Also used to describe alternating current through 360 space degrees.

**DENSITY:** Mass or weight per unit of volume, i.e.: Standard air .075 pounds per cubic foot.

**DISCHARGE LINE:** A tube used to convey the compressed refrigerant vapor from the compressor to the condenser inlet.

**DISCHARGE PRESSURE:** The pressure read at the compressor outlet. Also called head pressure or high pressure.

**DOE:** Department of Energy.

**DRY BULB TEMPERATURE:** Temperature read with an ordinary thermometer.

**ENERGY EFFICIENT RATIO (EER):** A ratio calculated by dividing the cooling capacity in BTUs per hour (BTUH) by the power input in watts or any given set of rating conditions, expressed in BTUH per watt (BTUH/watt).

**EVAPORATIVE COOLING:** The cooling effect of vaporization of a liquid in a moving air system.

**EVAPORATOR SUPERHEAT:** The actual temperature of the refrigerant vapor at the evaporator exit as compared to the saturated vapor temperature indicated by the suction pressure.

**EVAPORATOR:** A device in which a liquid refrigerant is vaporized. Some superheating usually takes place.

**FAHRENHEIT:** A temperature scale with freezing point of water 32° and the boiling point 212° at atmospheric pressure.

**FREEZING POINT:** The temperature at which the removal of any heat will begin a change of state from liquid to a solid.

**GAUGE PRESSURE:** Pressure measured with atmospheric pressure as a base.

## Terminology

**HEAT EXCHANGER:** A device for the transfer of heat energy from the source to the conveying medium.

**HEAT FLOW:** Heat flows from a warmer to a cooler substance. The rate depends upon the temperature difference, the area exposed and the type of material.

**HEAT OF COMPRESSION:** The heat added to a vapor by the work done on it during compression.

**HEAT OF THE LIQUID:** The increase in total heat (Enthalpy) per pound of saturated liquid as its temperature is increased above a chosen base temperature. (Usually -40°F for refrigerants). It is expressed in BTUs.

**HEAT TRANSFER:** The three methods of heat transfer are conduction, convection and radiation.

**HEAT:** A form of energy causing the agitation of molecules within a substance.

**HEATING SEASONAL PERFORMANCE FACTOR (HSPF):** The total heating output of a heat pump during its normal annual usage period for heating divided by the total electric power input in watt-hours during the same period.

**INCHES OF MERCURY:** Atmospheric pressure is equal to 29.92 inches of mercury.

**LATENT HEAT OF CONDENSATION:** The amount of heat energy, in BTUs, that must be removed to change the state of 1 pound of a vapor to 1 pound of liquid at the same temperature.

**LATENT HEAT OF FUSION:** The amount of heat energy, in BTUs, required to change the state of 1 pound of a liquid to 1 pound of solid at the same temperature.

**LATENT HEAT OF MELTING:** The amount of heat energy, in BTUs, that must be removed to change the state of 1 pound of a solid to 1 pound of liquid at the same temperature.

**LATENT HEAT OF VAPORIZATION:** The amount of heat energy, in BTUs, required to change the state of 1 pound of liquid to 1 pound of vapor at the same temperature.

**LATENT HEAT:** Heat that produces a change of state without a change in temperature. i.e.: Ice to water at 32°F; Water to steam at 212°.

**LIQUID LINE:** A tube used to convey the liquid refrigerant from the condenser outlet to the refrigerant control device of the evaporator.

**MANOMETER:** A tube filled with liquid used to measure pressure.

**MELTING POINT:** The temperature at which the addition of any heat will begin a change of state from a solid to a liquid.

**MERCURY MANOMETER:** Used to measure vacuum in inches of mercury.

**MICRON:** A unit used to measure high vacuums. One micron equals 1/25,400 of 1 inch mercury.

**PARTIAL PRESSURE:** The pressure exerted by an individual gas in a mixture.

**PRESSURE - TEMPERATURE RELATIONSHIP:** The change effected in temperature when pressure is changed or visa versa. Only used at saturated conditions. An increase in pressure results in a temperature increase. A decrease in temperature results in a pressure decrease.

**PRESSURE DROP:** The decrease in pressure due to friction of a fluid or vapor as it passes through a tube or duct.

**PSYCHROMETER:** A device having both a dry and a wet bulb thermometer. It is used to determine the relative humidity in a conditioned space. Most have an indexed scale to allow direct conversion from the temperature readings to the percentage of relative humidity.

**PSYCHROMETRIC CHART:** A chart on which can be found the properties of air under varying conditions of temperature, water vapor content, volume, etc.

**RADIATION:** The transfer of heat without an intervening medium. It is absorbed on contact with a solid surface.

**REFRIGERANT CONTROL:** A device used to meter the amount of refrigerant to an evaporator. It also serves as a dividing point between the high and low pressure sides of the system.

**REFRIGERANT:** A substance which produces a refrigerating effect while expanding or vaporizing.

**REFRIGERATION:** The transfer of heat from a place where it is not wanted to a place where its presence is not undesirable.

**RELATIVE HUMIDITY:** The percentage of water vapor present in a given quantity of air compared to the amount it can hold at its temperature.

**RELAY:** A device used to open and close an electrical circuit. The relay may be actuated by a bimetal electrically heated strip, a rod wrapped with a fine resistance wire causing expansion when energized, a bellows actuated by expansion of a fluid or gas or an electromagnetic coil.

**SATURATED VAPOR:** Vapor in contact with a liquid.

**SATURATION:** A condition of stable equilibrium of a vapor and a liquid.

**SEASONAL ENERGY EFFICIENCY RATIO (SEER):** The total cooling of a central unitary air conditioner or unitary heat pump in BTUs during its normal annual period for cooling divided by the total electric energy input in watt-hours during the same period.

**SENSIBLE HEAT:** Heat that can be measured or felt. Sensible heat always causes a temperature rise.

**SOUND RATING (SR):** A tone corrected A-weighted sound power level expressed in bels. The Sound Rating is based on tests performed at Standard Rating Conditions (cooling).

**SPECIFIC HEAT:** The amount of heat necessary to change the temperature of 1 pound of substance 1°F.

**SPECIFIC VOLUME:** The volume of a substance per unit of mass. i.e.: standard air 13.33 cubic feet per pound. The reciprocal of density.

**STANDARD AIR DENSITY:** .075 pounds per cubic foot. Equivalent to dry air at 70°F and at sea level pressure.

**STATE CONDITION:** Substances can exist in three states – Solid, Liquid or Vapor.

**SUB-COOLING:** Cooling of a liquid, at a constant pressure, below the point at which it was condensed.

**SUCTION LINE:** A tube used to convey the refrigerant vapor from the evaporator outlet to the suction inlet of a compressor.

**SUCTION PRESSURE:** The pressure read at the inlet side of a compressor. Also called back pressure or low side pressure.

**SUPERHEAT:** Heat added to a vapor after all liquid has been vaporized.

**TEMPERATURE:** A measure of heat intensity.

**THERMOSTAT:** A switch to close and open a circuit to indicate or terminate operation of a heating or air conditioning system.

**THERMOSTATIC EXPANSION VALVE:** Refrigerant control which monitors the flow rate according to the superheat at the evaporator outlet.

**TON OF REFRIGERATION:** The amount of heat necessary to completely melt 1 ton of 32°F ice in 24 hours. 200 BTUs per minute; 12,000 BTUs per hour; 288,000 BTUs in 24 hours. This is based on the latent heat fusion for ice which is 144 BTUs per pound.

**TOTAL HEAT:** (Enthalpy) The total heat energy in a substance. The sum of sensible and latent heat.

**TOTAL PRESSURE:** The sum of all partial pressures in a mixture of gases.

**VACUUM:** Any pressure below atmosphere pressure.

**WATER MANOMETER:** Used to measure pressure in inches of water.

**WET BULB TEMPERATURE:** Temperature read with a thermometer whose bulb is encased in a wetted wick.

## Alternate Ways To Size ERVS / HRVS

Traditionally, square footage of a home was needed to correctly size an ERV or HRV (Energy Recovery Ventilator, Heat Recovery Ventilator). If you don't know the square footage of your home, there is an easier way to size the ERV or HRV that you need to get the job done.

Either of the methods below give a result that relates to the CFMs (cubic feet per minute) that the ventilator unit can move with it's internal fans. For example, the HONEYWELL HR150B 1005 Heat Recovery Ventilator is rated 150 CFM. The Fantech Heat Recovery Ventilator Model SHR 2005R will do 168 CFM.

### Traditional Method - Square Footage

ERVs/HRVs are typically sized to ventilate the whole house at a minimum of .35 air changes per hour. To calculate minimum CFM requirements, simply take the square footage of the house (including basement) and multiply by the height of the ceiling to get cubic volume. Then, divide by 60 and multiply by .35.

### Alternate Method - Room Count

With the room count method, each room in the home is assigned a certain number of CFMs. When the values from the rooms are added together - the total number of required CFMs are the result. Use the chart below to figure the number of CFMs needed to properly size your ERV or HRV.

ROOM	NO. OF ROOMS	CFM (L/s)	CFMs REQUIRED
Master Bedroom		x 20 CFM (10 L/s)	
Basement	Yes or No	If yes add CFM (10 L/s)	
Bedrooms		x 10 CFM (5 L/s)	
Living Room		x 10 CFM (5 L/s)	
Other		x 10 CFM (5 L/s)	
Kitchen		x 10 CFM (5 L/s)	
Bathroom		x 10 CFM (5 L/s)	
Laundry Room		x 10 CFM (5 L/s)	
Utility Room		x 10 CFM (5 L/s)	

Total Ventilation Required (add last column) \_\_\_\_\_

## Exhaust Fans

PART NO.	DOWN BLAST, ROOF MOUNTED, DIRECT DRIVE FAN	VOLTAGE	MAX CFM	WEIGHT LBS.	ROOF MOUNTED DAMPER	FLAT ROOF CURB, INSULATED	115V		230V	
64408	FAN 5DDD085A 8"	115V 1 PH	417	26	5ACC12RD	5ACC17FT	5ACC03SC		x	
59551	FAN 5DDD10AA 10"	115V 1 PH	944	44	5ACC12RD	5ACC17FT	5ACC03SC		x	
59549	FAN 5DDD12CA 12"	115V 1 PH	1744	55	5ACC15RD	5ACC20FT	5ACC06SC		x	
62624	FAN 5DDD13DB 13"	115/230V 1 PH	2223	66	5ACC15RD	5ACC20FT	RPE10			RPE210
65287	FAN 5DDD16DB 16"	115/230V 1 PH	2913	149	5ACC15RD	5ACC24FS	RPE10			RPE210
69242	FAN 5DDD18EB 18"	115/230V 1 PH	4030	164	5ACC19RD	5ACC28FS	RPE10			RPE210

\*Call for pricing.

### Dimensions

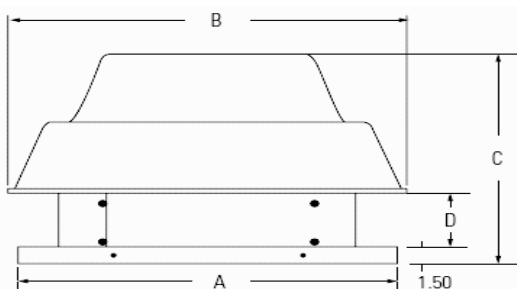

### 5ACC..RD

#### Roof Mount Damper

Manufactured from 19-gauge galvanized steel fram 2" deep with 1" flange. For quiet operation aluminum blades have felted edges. Pre-punched conduit hole knock-out.



### Specification Data

MODEL	A	B	C	D
5DDD 085A	19"	18 7/8"	13 1/4"	3 1/2"
5DDD 106A	19"	22 3/8"	16 1/2"	3 3/8"
5DDD 10AA	19"	22 3/8"	16 1/2"	3 3/8"
5DDD 12CA	22"	24 1/4"	17 1/8"	4"
5DDD 13DB	22"	25 5/8"	18 1/8"	4 3/8"
5DDD 15CA	26"	27 1/8"	18 1/2"	4 3/8"
5DDD 16DB	26"	29 3/4"	20 1/4"	4 3/4"
5DDD 18EB	30"	31 5/8"	21 3/8"	5 5/8"

MODEL	FAN SIZE	RECOMMENDED ROOF OPENING	OUTSIDE FLANGE	WEIGHT, LBS	ITEM #
5ACC12RD	10"	12 1/2" x 12 1/2"	12" x 12"	3	47196
5ACC15RD	12", 13"	15 1/2" x 15 1/2"	15" x 15"	4	47203
5ACC19RD	15", 16"	19 1/2" x 19 1/2"	19" x 19"	5	47210
5ACC23RD	18", 20"	23 1/2" x 23 1/2"	23" x 23"	9	47215



## Geothermal Verification Sheet

All geothermal units are built to order based on your specifications. Therefore, they are non-returnable and non-cancellable. Please review this sheet carefully before signing.

Customer name: \_\_\_\_\_ PO #: \_\_\_\_\_

Ship to: \_\_\_\_\_

Unit model number: \_\_\_\_\_

Compressor stages:  single stage  two stage

Tonnage: \_\_\_\_\_ Unit voltage: \_\_\_\_\_

Heat transfer type:  water-to-air  water-to-water

Unit configuration:  packaged  interior split  exterior split

Heat exchanger:  copper  cupronickel

Supply location:  top  rear  bottom  
 end  side  N/A

Return location:  left  right

Blower type:  PSC  ECM  X-13 (5 spd. ECM)  
 oversized PSC  oversized ECM

Back-up heat: \_\_\_\_\_

Accessories: \_\_\_\_\_

Options:

- no hot water, no Intellistart
- hot water with pump and no Intellistart
- hot water with pump and Intellistart
- Intellistart only

**I agree that the unit ordered is correct and understand that geo-thermal products are non-returnable and non-cancellable once ordered.**

Signature: \_\_\_\_\_ Date: \_\_\_\_\_

Printed name: \_\_\_\_\_

## Metal Flue Venting

### Integrated Furnace Control Menu

**CLEARING THE LAST 6 FAULTS:**  
To clear the stored faults, scroll to the last 6 faults menu, enter the menu by scrolling to the right and hold the "Option" key for at least 5 seconds. Release and a set of 3 dashes will be seen 3 times. This confirms the faults have been cleared

**SETTING UP YOUR SYSTEM:**  
To change any factory default value, first remove any "call" from the furnace and allow any fan off delays to finish. (I dL should be seen on the display)  
Scroll to the selected Menu item by momentarily depressing the "MENU" key and then depress the "OPTION" key to the desired setting. Then momentarily depress the "MENU" key again to save the change.

Gas Heating CFM shown is 2<sup>nd</sup> stage airflow, 1<sup>st</sup> stage airflow is ~80% of the selected 2<sup>nd</sup> stage airflow and cannot be adjusted.  
Gas heating CFM can be adjusted while the unit is operating in gas heat mode to enable the technician to quickly adjust to the manufacturer's suggested heat rise across the heat exchanger.  
**Multiply** the value shown by 10 for actual airflow

Model	Gas Heating CFM [ ]=Default
S9V2B040J3PS	088 [088], 140, 065, 083
S9V2B060J3PS	103 [103], 113, 146, 080
S9V2B060J4PS	116 [116], 159, 099, 109
S9V2B080J3PS	138 [138], 148, 120, 133
S9V2B080J4PS	126 [126], 133, 146, 120
S9V2B080J5PS	145 [145], 156, 208, 119
S9V2C100J4PS	183 [183], 190, 145, 162
S9V2C100J5PS	198 [198], 215, 225, 159
S9V2D120J5PS	195 [195], 225, 156, 185

Model	Downflow
S9V2B040D3PS	088 [088], 095, 140, 065
S9V2B060D3PS	103 [103], 113, 146, 080
S9V2B080D3PS	138 [138], 148, 120, 133
S9V2B080D4PS	126 [126], 133, 148, 120
S9V2C100D4PS	175 [175], 189, 131, 167
S9V2C100D5PS	187 [187], 225, 152, 180
S9V2D120D5PS	225 [225], 175, 185, 195

Model	ODT Options [ ]= Default
S9V2B040J3PS	3T[3T], 1.5T, 2T, 2.5T
S9V2B060J3PS	3T[3T], 1.5T, 2T, 2.5T
S9V2B060J4PS	4T[4T], 2.5T, 3T, 3.5T
S9V2B080J3PS	3T[3T], 3.5T, 2T, 2.5T
S9V2B080J4PS	4T[4T], 2.5T, 3T, 3.5T
S9V2C100J4PS	5T[5T], 3.5T, 4T, 4.5T
S9V2C100J5PS	5T[5T], 3.5T, 4T, 4.5T
S9V2D120J5PS	5T[5T], 3.5T, 4T, 4.5T

Model	Downflow
S9V2B040D3PS	3T[3T], 1.5T, 2T, 2.5T
S9V2B060D3PS	3T[3T], 1.5T, 2T, 2.5T
S9V2B080D3PS	3T[3T], 3.5T, 2T, 2.5T
S9V2B080D4PS	4T[4T], 2.5T, 3T, 3.5T
S9V2C100D4PS	4T[4T], 2.5T, 3T, 3.5T
S9V2C100D5PS	5T[5T], 3.5T, 4T, 4.5T
S9V2D120D5PS	5T[5T], 3.5T, 4T, 4.5T

CFM per Ton selections range from 290 – 450  
**Important:**  
When applied with zoning or a VSPD outdoor unit, the CFM/Ton must be set to 400

### S9V2 Control System Menu

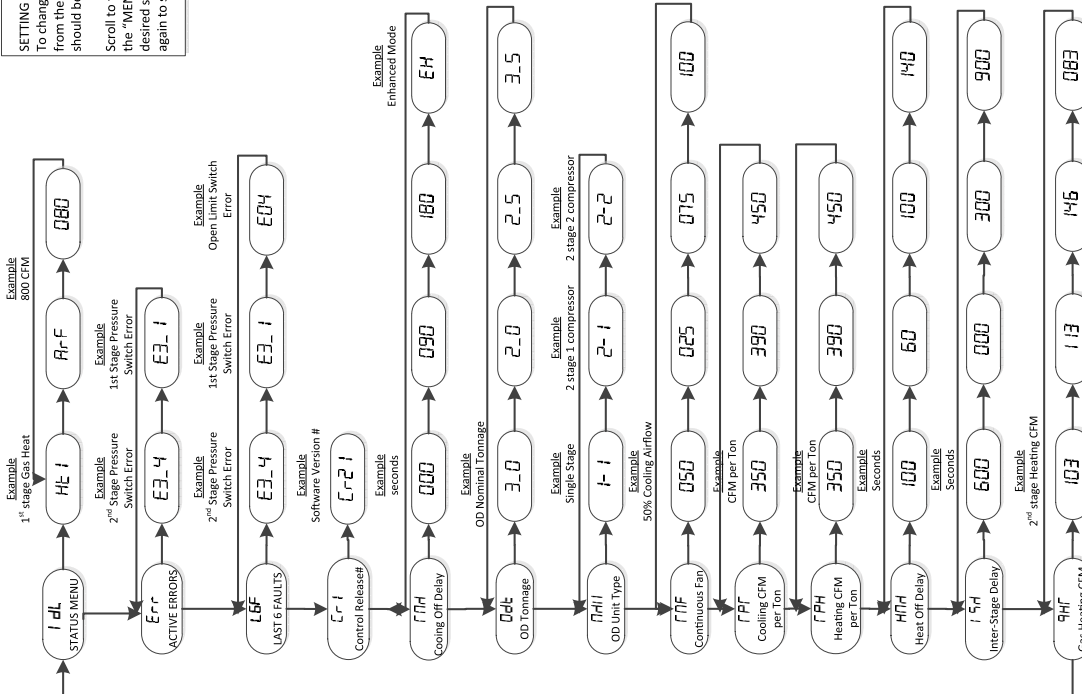

## Metal Flue Venting

### S9V2 Examples of System Status

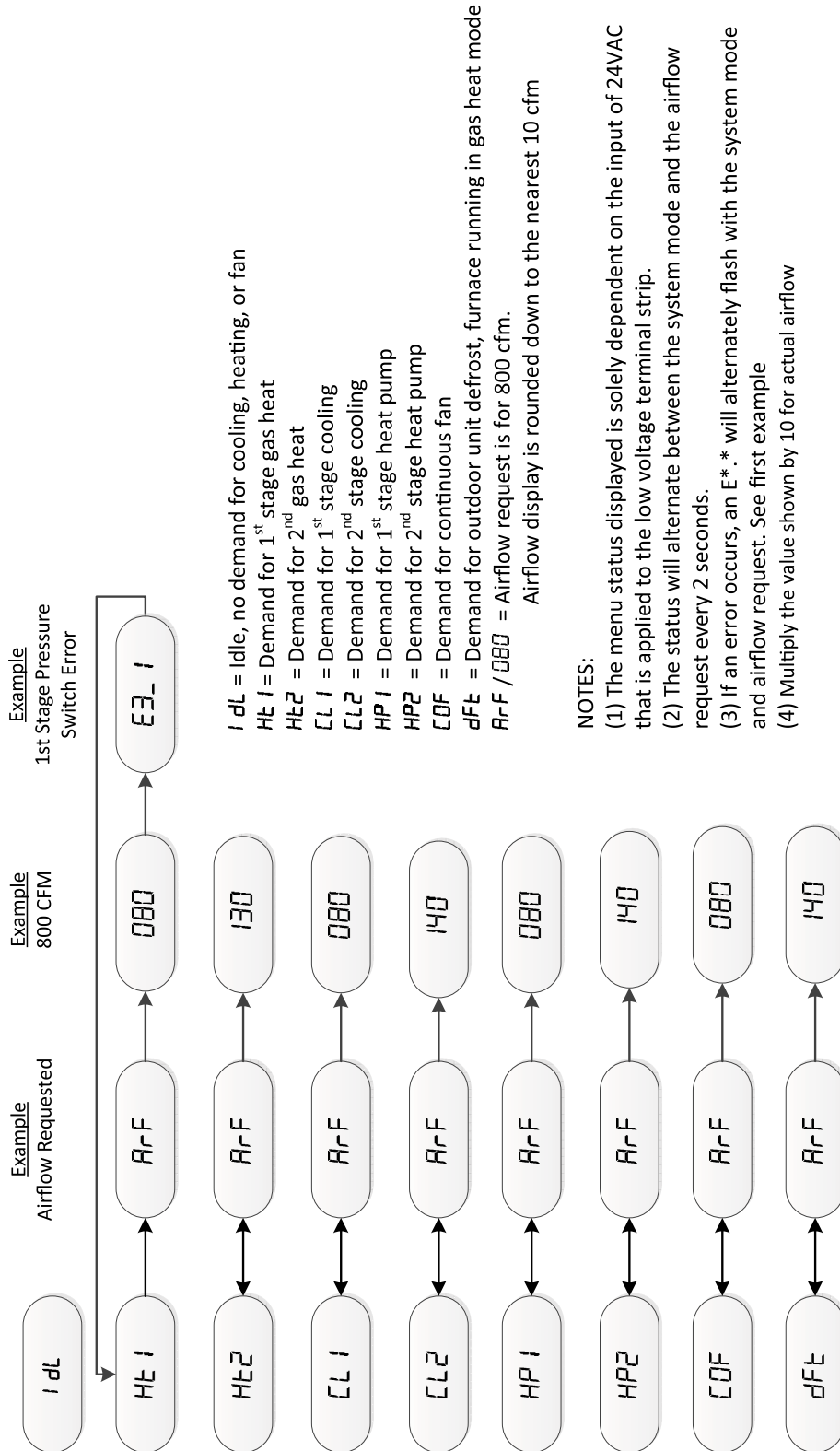

## Metal Flue Venting

Note: During run test mode, depressing the option key will allow the user to hold (HLD) that test sequence if measurements want to be taken. The exception is RU3 (ignitor).



### Run Test Mode:

To enter Run Test Mode, scroll to *rUn* using the Menu key, then push the option key. The LED will flash *rUn* three times, then begin the test.

To exit the test mode, momentarily push the Menu key, cycle power to the furnace, or make a valid thermostat call for capacity or fan.

### Sequence of Run Test Mode

*rU1* - Turns the inducer on in 1<sup>st</sup> stage for 30 seconds

*rU2* - Turns on the inducer on 2<sup>nd</sup> stage for 30 seconds

*rU3* - Turns the ignitor on for 10 seconds

*rU4* - Turns the circulating blower on 1st stage compressor speed for 10 seconds

*rU5* - Turns the circulating blower on 2nd stage compressor speed for 10 seconds

*rU6* - Turns the circulating blower on 1<sup>st</sup> stage gas heat speed for 10 seconds

*rU7* - Turns on the circulating blower on 2<sup>nd</sup> stage gas heat speed for 10 seconds

The above sequence will repeat two more times unless the Run Test Mode is exited, see above

**Important:** The Run Test Mode does not test fire the furnace or bring the outdoor unit on. It is designed to allow the technician to observe each mode to ensure the IFC, inducer, and circulating blower are performing as intended.

## Troubleshooting Flowchart Index

IFC Component Layout

Getting Started

### **Error Codes**

E2.1 – Retries Exceeded (flame never sensed)

E2.2 – Recycles Exceeded (loss of flame after being sensed)

E3.1 – Shorted Pressure Switch, 1<sup>st</sup> Stage

E3.2 – Open Pressure Switch, 1<sup>st</sup> Stage

E3.3 – Shorted Pressure Switch, 2<sup>nd</sup> Stage

E3.4 – Open Pressure Switch, 2<sup>nd</sup> Stage

E04 – Open Thermal Limit

E04 – Flame Rollout

E05 – Flame Detected , should not be present

E6.1 – Reversed Polarity (High Voltage)

E6.2 – Faulty Ground

E6.3 – Igniter Circuit

E7.1 – 1<sup>st</sup> Stage Gas Valve (MVL) energized when it should not be

E08 – Flame Current Low, operation allowed

E09 – Open Inducer Limit OR Condensate Switch

E11 – See troubleshooting Instructions

E13 – Blower HP / OEM Mismatch

E15 – PM Data and Local copy corrupted

E18 – Blower Communication failure on the IFC

## Metal Flue Venting

# FLEXI-LINER®

## FLEXI-LINER® SIZER Corrugated Chimney Liner for Gas Fired Appliances

### SINGLE APPLIANCE

Height, Ft "H"	Connector Type: Double or Single Wall "C"	Lateral Offset "L"	FLEXI-LINER Diameter "D" (inches)																				
			3"			4"			5"			5.5"			6"			7"			8"		
			Appliance Input Rating Limits (x1000 BTU/h) Reduced 20% from Type B Vent Tables																				
		FAN		NAT		FAN		NAT		FAN		NAT		FAN		NAT		FAN		NAT			
		Min	Max	Max	Min	Max	Max	Min	Max	Max	Min	Max	Max	Min	Max	Max	Min	Max	Max	Min	Max	Max	
15'	Double	2"	11	55	38	15	109	74	20	181	120	21	226	150	22	271	180	38	380	253	45	506	331
		5"	22	52	36	30	104	70	39	175	114	44	220	144	49	264	174	64	370	240	76	496	322
		10"	29	47	33	40	97	66	51	165	108	58	208	137	64	252	166	84	356	230	99	480	309
	Single	2"	38	55	38	57	109	74	80	180	119	98	225	149	115	270	179	148	378	251	187	505	330
		5"	51	50	35	75	102	69	102	173	112	123	217	143	144	261	174	182	367	238	231	493	320
		10"	NA	NA	NA	95	93	63	128	161	105	155	204	134	182	246	162	228	350	227	284	474	305
25'	Double	2"	10	62	43	14	126	85	16	213	140	18	268	176	19	324	212	30	458	296	37	615	402
		5"	21	59	41	29	21	82	37	207	134	42	261	170	46	315	206	60	448	289	71	603	394
		10"	28	54	38	38	113	76	49	196	128	55	249	162	61	302	196	79	432	277	93	585	380
	Single	2"	37	62	42	56	125	84	77	212	139	94	267	175	111	322	211	142	455	294	179	612	400
		5"	50	57	40	73	119	80	99	204	132	119	258	168	139	312	204	175	444	286	220	599	391
		10"	NA	NA	NA	92	109	74	124	191	126	149	244	159	174	296	192	218	424	273	271	577	375
30'	Double	2"	9	65	45	13	133	90	14	226	148	16	286	186	18	346	224	27	490	315	33	661	428
		5"	21	62	43	28	128	86	36	220	141	41	278	180	45	337	218	58	480	308	69	649	419
		10"	27	56	40	37	120	82	48	210	137	54	267	173	59	324	209	77	464	297	91	630	406
	Single	2"	37	64	45	55	131	89	76	225	146	93	284	185	109	343	223	139	488	314	175	658	426
		5"	49	59	42	72	126	85	98	217	138	117	275	178	136	334	217	171	476	306	215	645	417
		10"	NA	NA	NA	91	115	78	122	204	134	147	261	170	171	318	206	213	456	294	265	622	401
35'	Double	2"	9	66	46	13	136	92	14	234	152	16	296	192	17	359	231	26	511	325	31	691	444
		5"	21	63	NA	28	131	89	36	227	146	40	289	186	45	350	225	57	500	319	68	679	435
		10"	27	57	NA	37	124	84	47	217	141	53	277	178	58	337	216	76	484	308	90	660	422
	Single	2"	37	65	46	55	135	91	75	232	151	92	294	190	108	356	230	138	508	324	173	688	442
		5"	49	60	NA	72	129	87	97	224	143	116	285	184	135	347	224	169	496	316	212	674	433
		10"	NA	NA	NA	91	118	NA	121	211	138	145	271	175	169	330	213	211	476	304	262	651	417
45'	Double	2"	8	68	48	12	143	96	14	249	161	15	317	203	16	385	244	23	552	346	28	750	476
		5"	20	65	NA	27	138	93	35	242	155	39	309	197	44	376	239	56	541	340	66	738	468
		10"	26	60	NA	36	131	89	46	232	148	51	298	190	57	364	231	74	525	330	87	719	455
	Single	2"	36	66	48	54	141	95	74	247	160	90	315	201	105	383	243	135	549	344	170	747	474
		5"	48	63	NA	71	136	91	95	239	153	114	306	195	132	373	237	168	537	337	207	733	465
		10"	NA	NA	NA	90	125	NA	119	228	145	142	291	186	164	356	227	206	517	325	256	709	450

### MULTIPLE APPLIANCES

Height, Ft "H"	Connector Type: Double or Single Wall "C"	FLEXI-LINER Diameter "D" (inches)																				
		4"			5"			5.5"			6"			7"			8"					
		Combined Appliance Input Rating Limits (x1000 BTU/h) Reduced 20% from Vertical Common Vent																				
		FAN Only		FAN & NAT Only		FAN Only		FAN & NAT Only		FAN Only		FAN & NAT Only		FAN Only		FAN & NAT Only		FAN Only		FAN & NAT Only		
		Min	Max	Max	Min	Max	Max	Min	Max	Max	Min	Max	Max	Min	Max	Max	Min	Max	Max	Min	Max	Max
15'	Double	100	90	73	156	131	115	191	157	140	226	182	165	342	282	224	445	355	292			
	Single	97	86	70	151	127	112	186	152	136	220	177	160	333	274	219	435	347	286			
25'	Double	116	104	88	184	157	138	227	189	168	270	221	198	409	341	268	537	434	350			
	Single	111	100	84	178	152	135	220	183	163	262	214	192	398	332	261	524	423	342			
30'	Double	122	110	94	195	168	148	242	203	181	289	238	213	438	367	288	576	468	376			
	Single	116	106	90	189	162	144	235	196	175	280	229	206	426	357	279	562	456	367			
35'	Double	125	113	97	202	175	154	252	212	188	301	249	222	457	385	301	603	492	392			
	Single	119	109	93	195	168	150	243	204	182	291	239	214	444	374	291	588	479	382			
45'	Double	131	119	104	216	188	165	271	230	202	325	271	239	494	420	326	656	541	424			
	Single	124	114	99	208	180	161	261	220	195	314	260	229	480	407	316	640	526	413			

See Rigid Connector Sizing Table below for Multiple Appliance Systems

## Metal Flue Venting

**FLEXI-LINER®**

**Aluminum Flexible Chimney Liner and Gas Vent Connector**

**Installation Instructions**

### RIGID CONNECTOR - SIZING INFORMATION

#### VENT CONNECTOR CAPACITIES

#### FOR MULTIPLE CATEGORY 1 APPLIANCES CONNECTED TO A COMMON VENT

System Height, Ft	Connector Type: Double or Single Wall	Connector Rise, Ft	3"			4"			5"			6"		
			Fan		Nat	Fan		Nat	Fan		Nat	Fan		Nat
			Min	Max	Max	Min	Max	Max	Min	Max	Max	Min	Max	Max
15	Double	1	21	50	30	33	89	53	47	142	83	64	220	120
		2	22	53	35	35	96	63	49	153	99	66	235	142
		3	24	55	40	36	102	71	51	163	111	68	248	160
	Single	1	NA	NA	29	79	87	52	116	138	81	177	214	116
		2	NA	NA	34	83	94	62	121	150	97	185	230	138
		3	NA	NA	39	87	100	70	127	160	109	193	243	157
25	Double	1	21	58	32	32	106	58	46	169	90	61	267	130
		2	22	61	38	34	112	68	48	179	107	63	279	154
		3	23	63	43	35	117	77	49	187	120	65	290	173
	Single	1	48	58	31	78	104	56	114	164	87	172	258	125
		2	52	61	37	82	109	66	119	174	104	180	271	148
		3	55	63	41	86	113	74	124	183	117	188	282	168
30	Double	1	20	62	33	31	113	59	45	181	93	60	288	134
		2	21	64	39	33	118	70	47	190	110	62	299	158
		3	22	66	44	34	123	79	48	198	124	64	309	178
	Single	1	47	60	31	77	110	57	112	175	89	169	278	129
		2	51	62	37	81	115	67	117	185	106	177	290	152
		3	54	64	42	85	119	76	122	193	120	185	300	172
35	Double	1	20	64	34	31	118	60	45	190	95	59	303	137
		2	21	66	40	33	123	72	47	198	112	61	314	162
		3	22	68	45	34	128	81	48	206	127	63	323	182
	Single	1	47	62	32	77	115	58	111	183	91	167	293	131
		2	51	64	38	81	119	68	116	193	108	175	304	155
		3	54	66	43	85	123	78	121	200	121	183	313	176
45	Double	1	19	69	35	30	128	63	44	207	99	58	334	142
		2	21	71	42	32	132	75	46	215	117	60	343	169
		3	22	73	47	33	137	84	47	221	132	62	352	190
	Single	1	46	67	33	76	124	59	110	199	94	164	322	135
		2	50	69	39	80	128	71	115	208	111	172	331	161
		3	53	70	44	84	132	81	120	214	122	180	340	183

NA means "Not Allowed"

## Metal Flue Venting

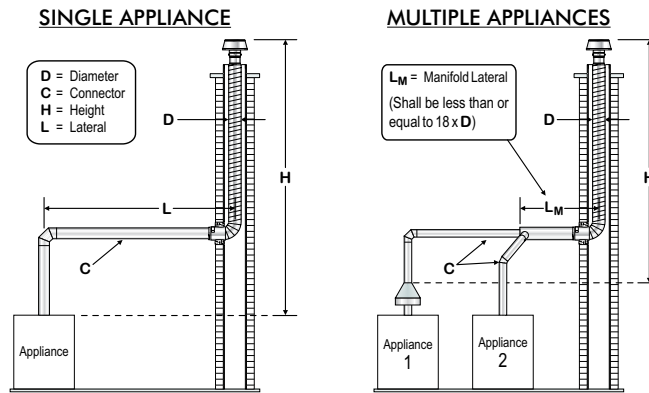

### GENERAL VENTING REQUIREMENTS

- A1. The air space around an installed Flexi-Liner System must not be used to vent other appliances.
- A2. A Flexi-Liner System venting more than one appliance shall not be smaller in diameter than the outlet of the largest appliance being served.
- A3. For single appliance installations, the Flexi-Liner System may be smaller in diameter than the outlet of the appliance being served, providing:
  - a) the vent height is at least 10ft.
  - b) the liner size is not more than one size smaller.
  - c) the "FAN MAX" is reduced by 10% if the appliance is "fan assisted".
  - d) the outlet is larger than 4" if the appliance is "natural draft".
- A4. Reduce Flexi-Liner capacity for elbows (turns) as follows:
  - A4.1. Single Appliance (two 90° elbows for total vent system are factored into chart)
    - a) In USA - for each additional elbow up to 45°, reduce capacity by 5%.  
- for each additional elbow 45°-90°, reduce capacity by 10%.
    - b) In CDA - for each additional elbow 90° reduce capacity by 10% for NAT and 15% for FAN.
  - A4.2. Multiple Appliances (90° turn at the bottom of liner is factored into chart)
    - a) In USA - for each elbow in the common vent up to 45°, reduce capacity by 5%.  
- for each elbow 45°-90°, reduce capacity by 10%.
    - b) In CDA - for each 90° elbow in the common vent, reduce capacity by 10% for NAT and 15% for FAN.

Common Vent manifold fitting is part of the connector sizing coming to it.
- A5. Do not use these tables if the vent system contains any device (such as a vent damper, draft regulator or heat reclaimer, etc.), which retards the flow of vent gases. Refer to instructions provided by the manufacturer of the device for vent instructions.
- A6. Interpolation between the table entries is permitted, extrapolation beyond the table entries is not permitted.
- A7. Vent connector sizes for multiple appliances are derived from tables included in the following national gas codes: NFPA 54 (USA) and B149.1 (CDA).
- A8. These tables are derived from the National Fuel Gas Code (NFPA 54 & CSA-B149). Current code data and information will supercede these sizing instructions if there is any discrepancy between them.

### ADDITIONAL COMMENTS

- B1. Flexi-Liner System is UL/ULC Listed for relining existing masonry or factory-built chimneys and vents serving Category I natural gas or propane fired appliances.
- B2. Insulating of Flexi-Liner System is a benefit to the installation but not always essential to effective operation of this venting system. Consult the Flexi-Sleeve installation instructions for application guidelines.
- B3. The use of a "Y" fitting rather than a "T" fitting is recommended when common venting into a manifold system.
- B4. AVOID CONDENSATION and/or SPILLAGE OF FLUE GASES:
  - a) Install Flexi-Liner as per installation instructions.
  - b) Set up appliances as per appliance installation instructions.
- B5. Contact local authorities for restrictions and regulations in your area.
- B6. Venting gas fired appliances into masonry chimneys is prohibited, unless a Listed liner such as Flexi-Liner, or a tile liner conforming to Code is utilized. Oversized, misaligned and/or cracked tiles DO NOT constitute a Code liner.

Printed in Canada

**FLEXI-LINER®**